

WST-1 Controller (Intelligent)

W ST-1 Controller

The WST-1 controller is newly developed device that matches a range of dual-power transfer switches. It has excellent performance and powerful functions that include delay, over and under voltage protection, open phase protection, overcurrent protection, line voltage and current display, power indication, remote clearing, automatic generator startup, a 485 communications interface, timing, automatic input and recovery as well as automatic input and nonautomatic recovery.

WST-1 Controller Installation dimensions

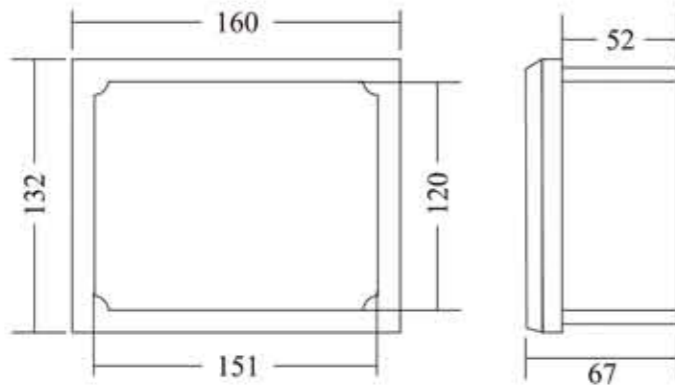

WST-3 Controller

W ST-3 Controller

The WST-3 controller is an updated version of the original ATS-487 controller. It has powerful functions, excellent performance and is suitable for use with a range of dual-power transfer switches. Refer to the Controller Selection Sheet for the protection and display functions.

Installation dimensions

