

AMESCO

**HARDWARE
for INDUSTRY**

LOCK



1-571-A



A-1 Key

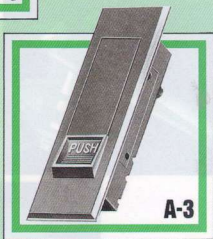

A-3

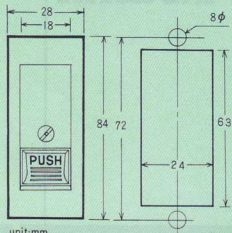

unit:mm

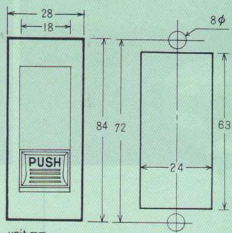

unit:mm



A-172-1

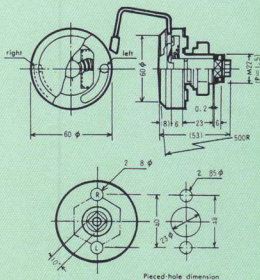

Faced hole dimension

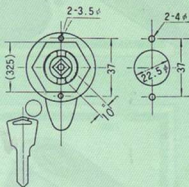
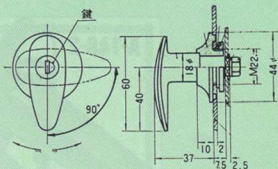

IRON PLATE

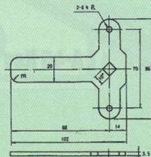

C-1025

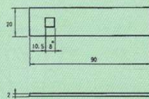

C-25K

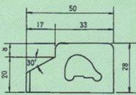

C-270-C

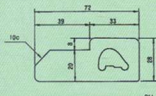

C-270A

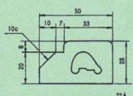

C-270-B

A-140-2

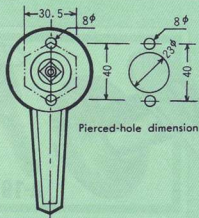

A-45 Key



A-45

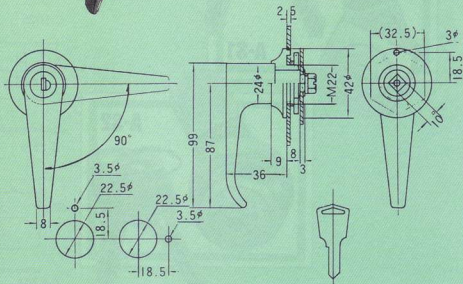

HINGES FLAT END

■ **MATERIALS**

Body: Solid Brass-chrome Plated
 Pin: Dia.6 Stainless Steel
 Screws: M6x8-4 Assembly
 Hexagon Head Pozi Drive

■ **DIMENSIONS**

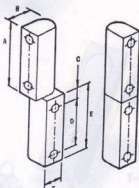

Item No.	mm	A	B	C	D	E	F
HC-50		25	16	6.5	13	25	12
HC-80		40	16	6.5	28.5	40	12



HC-80



HC-50

SCREW DRIVER TYPE

■ **DIMENSIONS**

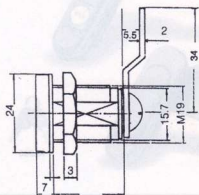
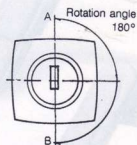

AS-1D

外形及安装孔尺寸 Dimensions of outline and cut out



AB102-1-1



AB102-2-1



K0200

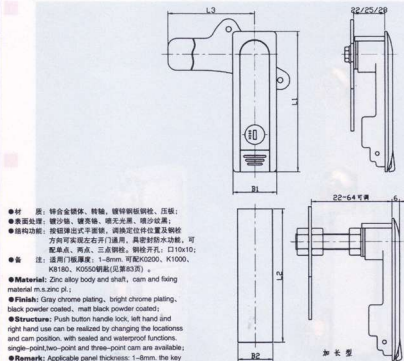

- 材 质: 锌合金本体, 转轴, 镀锌钢板锁体, 压铸;
- 表面处理: 镀锌粉, 镀锌粉, 喷光亮黑, 喷沙处理;
- 结构功能: 按钮弹出式平开锁, 调整定位位置及锁栓方向可实现左右开门通用, 具密封防水功能, 可配单点, 两点, 三点锁栓; 锁栓开孔: 口10x10;
- 备 注: 适用门框厚度: 1-4mm, 可配K0200、K1000、K8180、K0550锁匙(见第83页)。
- Material: Zinc alloy body and shaft, cam and fixing material m.s.zinc pl.;
- Finish: Gray chrome plating, bright chrome plating, black powder coated, matt black powder coated;
- Structure: Push button handle lock, left hand and right hand use can be realized by changing the locations and cam position, with sealed and waterproof functions, single-point, two-point and three-point cam are available;
- Remark: Applicable panel thickness: 1-4mm, the key K0200, K1000, K8180, K0550 are available(see page 83).

型号	尺寸	L1	L2	L3	B1	B2
AB102-1-1		150	141	140	38	30
AB102-2-1		110	102.5	100	34	27

专利号(Patent No): 200430021739.8

外形及安装孔尺寸 Dimensions of outline and cut out



K0200

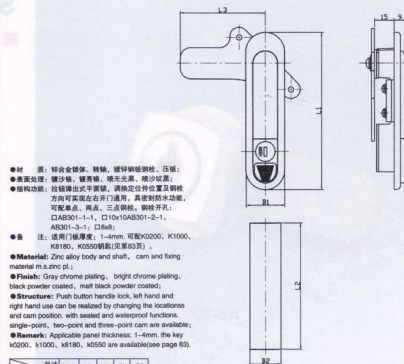

- 材 质: 锌合金本体, 转轴, 镀锌钢板锁体, 压铸;
- 表面处理: 镀锌粉, 镀锌粉, 喷光亮黑, 喷沙处理;
- 结构功能: 按钮弹出式平开锁, 调整定位位置及锁栓方向可实现左右开门通用, 具密封防水功能, 可配单点, 两点, 三点锁栓; 锁栓开孔: 口10x10AB301-1-1, AB301-2-1, AB301-3-1, 口8x8;
- 备 注: 适用门框厚度: 1-4mm, 可配K0200、K1000、K8180、K0550锁匙(见第83页)。
- Material: Zinc alloy body and shaft, cam and fixing material m.s.zinc pl.;
- Finish: Gray chrome plating, bright chrome plating, black powder coated, matt black powder coated;
- Structure: Push button handle lock, left hand and right hand use can be realized by changing the locations and cam position, with sealed and waterproof functions, single-point, two-point and three-point cam are available;
- Remark: Applicable panel thickness: 1-4mm, the key K0200, K1000, K8180, K0550 are available(see page 83).

型号	尺寸	L1	L2	L3	B1	B2
AB301-1-1		147	117	72	33	26.5
AB301-2-1		120.5	95.6	65	30	23.5
AB301-3-1		87.5	62.5	65	28.5	23.5

Dimensions of outline and cut out 外形及安装孔尺寸

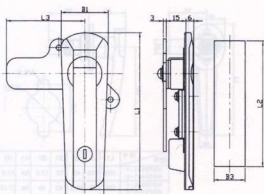

型号	尺寸	L1	L2	L3	B1	B2	B3
AB401-1-1		151	117	72	36	30	26.5
AB401-1-2		123	89.5	65	36.5	30	23.5
AB401-3-1		91	62.5	65	33	28.5	25.5

- 材料: 锌合金壳体、转轴、镀锌钢板衬板、压铸。
- 表面处理: 镀锌、喷粉、喷光、喷砂、喷砂、喷砂。
- 结构功能: 平衡轴, 调整定位件位置及锁棒方向可实现左右开门通用, 具密封防水功能, 可配单点、两点、三点锁。锁棒开孔: AB401-2-1口10x10; AB401-2-1小AB401-3-1 (2孔)。
- 备注: 适用门板厚度: 1-4mm, 可配K0200、K1000、K8180钥匙(见页83)。
- Material: Zinc alloy body and shaft, cam and facing material m.s.zinc pl.
- Finish: Gray chrome plating, bright chrome plating, black powder coated, matt black powder coated;
- Structure: Left hand and right hand use can be realized by changing the locations and cam position, with sealed and waterproof functions. Single-point, two-point and three-point cam are available;
- Remark: Applicable panel thickness: 1-4mm, the key K0200, k1000, k8180 are available(see page 83).

专利号(Patent No): 20043002



Dimensions of outline and cut out 外形及安装孔尺寸

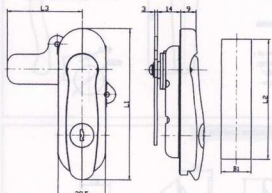

型号	尺寸	L1	L2	L3	B1
AB402-1-1		146	116.5	72	26.5
AB402-2-1		122	95.5	65	23.5
AB402-3-2		91	62.5	65	23.5

- 材料: 锌合金壳体、转轴、镀锌钢板衬板、压铸。
- 表面处理: 镀锌、喷粉、喷光、喷砂、喷砂、喷砂。
- 结构功能: 平衡轴, 调整定位件位置及锁棒方向可实现左右开门通用, 具密封防水功能, 可配单点、两点、三点锁。锁棒开孔: 2孔。
- 备注: 适用门板厚度: 1-4mm, 可配K0200、K1000钥匙(见页83)。
- Material: Zinc alloy body and shaft, cam and facing material m.s.zinc pl.
- Finish: Gray chrome plating, bright chrome plating, black powder coated, matt black powder coated;
- Structure: Left hand and right hand use can be realized by changing the locations and cam position, with sealed and waterproof functions. single-point, two-point and three-point cam are available;
- Remark: Applicable panel thickness: 1-4mm, the key K0200, k1000 are available(see page 83).



Dimensions of outline and cut out 外形及安装孔尺寸

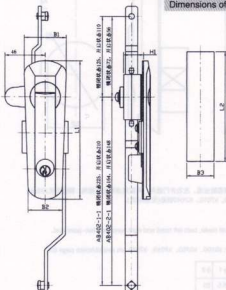

- 材料: 锌合金壳体、镀锌钢板衬板、传动轴、压铸。
- 表面处理: 镀锌、喷粉、喷光、喷砂、喷砂、喷砂。
- 结构功能: 平衡轴, 调整定位件位置及锁棒方向可实现左右开门通用, 具密封防水功能, 可配单点、两点、三点锁。锁棒开孔: AB403-1-1; AB403-2-1 (2孔)。
- 备注: 适用门板厚度: 1-4mm, 可配K0200、K1000、K8180钥匙(见页83)。
- Material: Zinc alloy body and shaft, cam, rod and facing material m.s.zinc pl.
- Finish: Gray chrome plating, bright chrome plating, black powder coated, matt black powder coated;
- Structure: Rod control lock, left hand and right hand use can be realized by changing the cam position, with sealed and waterproof functions. single-point, two-point and three-point cam are available;
- Remark: Applicable panel thickness: 1-4mm, the key K0200, k1000, k8180 are available(see page 83).

型号	尺寸	L1	L2	B1	B2	B3	H1
AB403-1-1		150	131	43	30	27	27
AB403-2-1		121	96	36.5	30	24	17.5





外形及安装孔尺寸 Dimensions of outline and cut out

- 材 质: 锌合金壳体, 螺母, 镀锌钢板钢板;
- 表面处理: 镀锌粉, 镀铬漆, 抛光亮黑, 哑光黑;
- 结构功能: L型把手, 锁座旋转60° 安装可实现左右开门通用, 也可配旋转90° 双锁芯, 两芯, 三点锁钩, 锁钩开孔AB701-1-1□10x10AB701-2-1, AB701-3-1□6x8;
- 配 注: 适用门厚度: 1-8mm, 可配K0200, K1000, K8180, 铜钩(见页83);
- Material: Zinc alloy body and nut, cam m.s. zinc pl.
- Finish: Gray chrome plating, bright chrome plating, black powder coated, matt black powder coated;
- Structure: L handle lock, left hand and right hand use can be realized by turning the lock base to 60° or 90°, single-point, two-point and three-point cam are available;
- Remark: Applicable panel thickness: 1-8mm, the key K0200, K1000, K8180, K8090 are available(see page 83).

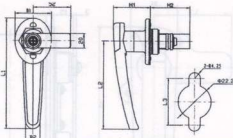

型号	尺寸	L1	L2	L3	B1	B2	H1	H2
AB701-1-1	AB701-1-2	150	119	40	50	17.5	50	41.5
AB701-2-1	AB701-2-2	120	96	30.5	40	15	46	31-3
AB701-3-1	AB701-3-2	101.5	78	32	37	14	45	31-3



外形及安装孔尺寸 Dimensions of outline and cut out

- 材 质: 锌合金壳体, 螺母, 镀锌钢板钢板;
- 表面处理: 镀锌粉, 镀铬漆;
- 结构功能: L型把手, 锁座旋转60° 安装并调换锁钩方向可实现左右开门通用;
- 配 注: 适用门厚度: 1-2mm;
- Material: Zinc alloy body and nut, cam m.s. zinc pl.
- Finish: Gray chrome plating, bright chrome plating;
- Structure: L handle lock, turn the lock base to 60° when installing, left hand and right hand use can be realized by changing the cam position;
- Remark: Applicable panel thickness: 1-2mm.

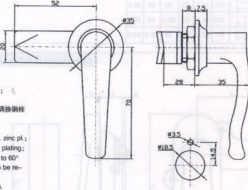

外形及安装孔尺寸 Dimensions of outline and cut out

- 材 质: PA-66螺母, 镀锌钢板钢板, 传动芯;
- 表面处理: 黑色;
- 结构功能: 半圆材料传动, 异形半圆控制芯, 带塑料弹性防尘盖, 左右开门通用, 可配两点和三点结构, 铜钩开孔□6x8;
- 配 注: 适用门厚度: 1-4.5mm, 可配K0100, K7030, K7010, K7040铜钩(见页83);
- Material: PA-66 body, cam and nut m.s. zinc pl.
- Surface color: Black;
- Structure: Flat control lock, double ball insert, plastic dust cover, both left hand and right hand use, two-point and three-point structures are available;
- Remark: Applicable panel thickness: 1-4.5mm, the key K0100, K0703, K7010, K7040 are available(see page 83).

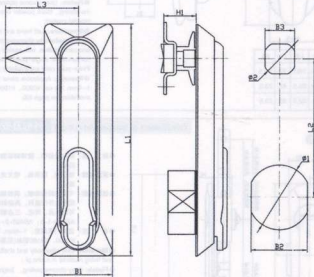

型号	尺寸	L1	L2	L3	B1	B2	B3	H1	H2
MS100-1-1		162	96.5	31.5	48	40.5	21.5	28	45.5
MS100-2-1		138	96.5	40	37	30	15.5	15.5	18

Dimensions of outline and cut out 外形及安装孔尺寸

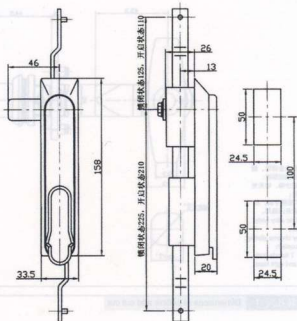

- 材 质: PA-66塑料, 镀锌钢板锁芯;
- 表面颜色: 黑色;
- 结构功能: 平圆连杆传动, 异形半圆柱锁芯, 带塑料锁芯防尘盖, 左右开门通用, 可配两点和三点锁钩; 锁钩开口8mm;
- 备 注: 适用门框厚度1-4mm, 可配K0100、K7030、K7010、K7040锁芯(见页83);
- Material: PA-66 body, cam m.s. zinc pl;
- Surface color: Black;
- Structure: Rod control lock, double bit insert, plastic dust cover, both left hand and right hand use, two-point and three-point structures are available;
- Remark: Applicable panel thickness: 1-4mm, the key K0100, K7030, K7010, K7040 are available(see page 83).



K0100

MS100-3

Dimensions of outline and cut out 外形及安装孔尺寸

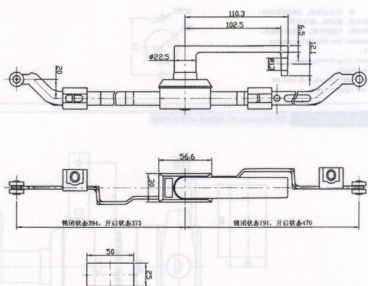

- 材 质: 锌合金锁体、齿轮盒, 镀锌钢板锁芯;
- 表面处理: 镀锌粉, 喷无光漆;
- 结构功能: L型的平锁, 左右开门通用;
- Material: Zinc alloy body and rod control, cam m.s. zinc pl;
- Finish: Gray chrome plating, black powder coat;
- Structure: L handle lock, both left hand and right hand use.



MS102C

Dimensions of outline and cut out 外形及安裝孔尺寸

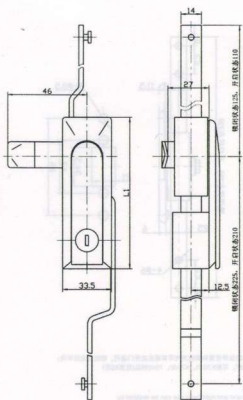

- 材 质：锌合金壳体，镀锌钢板锁体；
- 表面处理：喷沙喷，磷化无漆。
- 结构功能：手置连杆控制，调整锁杆方向及连杆位置可实现左右开门通用。可配两点或三点结构。
- 备 注：适用门框厚度1-3mm，可配K0600、K0200、K1000、K0100锁匙(见页83页)；铜杆开孔C类。
- Material: Zinc alloy body, cam m.s. zinc pl.;
- Finish: Gray chrome plating, black powder coat.
- Structure: Rod control lock, left hand and right hand use can be realized by changing the rod and cam position, two-point and three-point structures are available(see page 83);
- Remark: Applicable panel thickness: 1-3mm the key K0600、K0200、K1000、K0100 are available.

型号	尺寸	L1	L2	L3
MS103-1-1	152	152	94.5	49.5
MS103-2-1	131	74	49.5	
MS103-3-1	114	68	49.5	



Dimensions of outline and cut out 外形及安裝孔尺寸

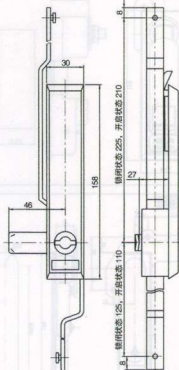

- 材 质：PA-66壳体，锌合金套轮套，镀锌钢板连杆、铜杆。
- 表面处理：黑色。
- 结构功能：手置连杆控制，调整锁杆方向可实现左右开门通用。可配单点、两点、三点锁。
- 备 注：适用门框厚度1-3mm，铜杆开孔C类。
- Material: PA-66 body, zinc alloy rod control, rod and cam m.s. zinc pl.
- Surface color: Black.
- Structure: Rod control lock, left hand and right hand use can be realized by changing the cam position, single-point, two-point and three-point cam are available.
- Remark: Applicable panel thickness: 1-3mm.





外形及安装孔尺寸 Dimensions of outline and cut out

- 材 质: 锌合金壳体, 镀锌钢板;
●表面处理: 镀锌板, 镀锌板;
●结构功能: L型把手, 可旋转90°安装并调换锁孔方向可实现左右开门通用;
- 备 注: 适用门框厚度: 1-3mm, 可配K0300, K1000, K0700, K8180锁匙(见页83);
- Material: Zinc alloy body, cam m.s. zinc pl.;
●Finish: Bright chrome plating, gray chrome plating;
- Structure: L handle lock, turn the lock base to 90° when installing, left hand and right hand use can be realized by changing the cam position;
- Remark: Applicable panel thickness: 1-3mm, the key K0300, K1000, K8180, K0700 are available(see page 83).



外形及安装孔尺寸 Dimensions of outline and cut out

- 材 质: 锌合金壳体, 镀锌钢板;
●表面处理: 镀锌板, 镀锌板;
●结构功能: L型把手, 可旋转90°安装并调换锁孔方向可实现左右开门通用;
- 备 注: 适用门框厚度: 1-3mm, 可配K0300, K0700, K1000, K8180锁匙(见页83);
- Material: Zinc alloy body and nut, cam m.s. zinc pl.;
●Finish: Bright chrome plating, gray chrome plating;
- Structure: L handle lock, turn the lock base to 90° when installing, left hand and right hand use can be realized by changing the cam position;
- Remark: Applicable panel thickness: 1-3mm, the key K0300, K0700, K1000, K8180 are available(see page 83).



外形及安装孔尺寸 Dimensions of outline and cut out

- 材 质: 锌合金壳体, 镀锌钢板;
●表面处理: 镀锌板, 镀锌板;
●结构功能: L型把手, 可旋转90°安装并调换锁孔方向可实现左右开门通用;
- 备 注: 适用门框厚度: 1-3mm, 可配K0300, K0700, K1000, K8180锁匙(见页83);
- Material: Zinc alloy body and nut, cam m.s. zinc pl.;
●Finish: Bright chrome plating, gray chrome plating;
- Structure: L handle lock, turn the lock base to 90° when installing, left hand and right hand use can be realized by changing the cam position;
- Remark: applicable panel thickness: 1-3mm, the key K0300, K0700, K1000, K8180 are available(see page 83).

Dimensions of outline and cut out 外形及安装孔尺寸

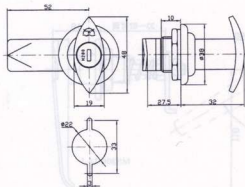

- 材 质: 锌合金壳体、螺母, 镀锌钢板钢钉;
- 表面处理: 镀锌粉, 镀锌粉;
- 结构功能: L型把手, 锁体旋转90° 安装并调换锁体方向可实现左右开门通用;
- 备 注: 适用门框厚度为: 1-2mm, 可配 K1000, K0200, K8180钢钉(见页83页);
- Material: Zinc alloy body and nut, cam m.s. zinc pl.
- Finish: Bright chrome plating, gray chrome plating;
- Structure: L handle lock, turn the lock base to 90° when installing, left hand and right hand use can be realized by changing the cam position;
- Remark: Applicable panel thickness: 1-2mm, the key K1000, K1000, K8180 are available(see page 83).



MS302B-1

Dimensions of outline and cut out 外形及安装孔尺寸

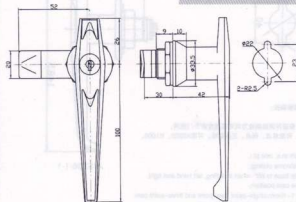

- 材 质: 锌合金壳体、螺母, 镀锌钢板钢钉;
- 表面处理: 镀锌粉, 镀锌粉;
- 结构功能: L型把手, 锁体旋转90° 安装并调换锁体方向可实现左右开门通用;
- 备 注: 适用门框厚度: 1-3mm, 可配K0200, K0200, K1000, K8180钢钉(见页83页);
- Material: Zinc alloy body and nut, cam m.s. zinc pl.
- Finish: Bright chrome plating, gray chrome plating;
- Structure: L handle lock, turn the lock base to 90° when installing, left hand and right hand use can be realized by changing the cam position;
- Remark: Applicable panel thickness: 1-3mm, the key K0200, K0200, K1000, K8180 are available(see page 83).



MS304-1-1

MS304-1-2

Dimensions of outline and cut out 外形及安装孔尺寸

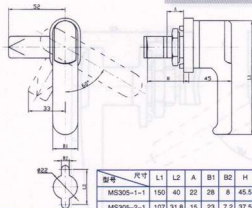

- 材 质: 锌合金壳体、螺母, 镀锌钢板钢钉;
- 表面处理: 镀锌粉, 镀锌粉;
- 结构功能: L型把手, 锁体旋转60° 安装并调换锁体位置可实现左右开门通用;
- 备 注: 适用门框厚度: 1-4mm, 锁体开孔: 10x10, 可配K0200, K1000, K8180钢钉(见页83页);
- Material: Zinc alloy body and nut, cam m.s. zinc pl.
- Finish: Bright chrome plating, gray chrome plating;
- Structure: L handle lock, turn the lock base to 90° when installing, left hand and right hand use can be realized by changing the lock location;
- Remark: Applicable panel thickness: 1-4mm, the key K0200, K1000, K8180 are available(see page 83).

型号	尺寸	L1	L2	A	B1	B2	H
MS305-1-1	150	40	22	28	8	8	45.5
MS305-2-1	107	31.8	15	23	7.2	37.5	

专利号: 99322661.2



MS305-1-1

Dimensions of outline and cut out 外形及安装孔尺寸

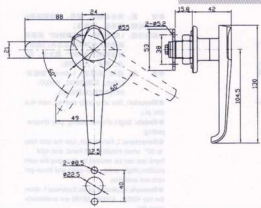

- 材 质: 锌合金壳体、螺母, 镀锌钢板钢钉;
- 表面处理: 镀锌粉, 镀锌粉;
- 结构功能: L型把手, 锁体旋转60° 安装并调换锁体方向可实现左右开门通用;
- 备 注: 适用门框厚度: 1-4mm, 可配单点、两点、三点锁体, 可配K0200, K1000, K8180钢钉(见页83页);
- Material: Zinc alloy body and nut, cam m.s. zinc pl.
- Finish: Bright chrome plating, gray chrome plating;
- Structure: L handle lock, turn the lock base to 60° when installing, left hand and right hand use can be realized by changing the cam position;
- Remark: Applicable panel thickness: 1-4mm, single-point, two-point and three-point cam are available, the key K0200, K1000, K8180 are available(see page 83).



MS306-2-1



外形及安装孔尺寸 | Dimensions of outline and cut out

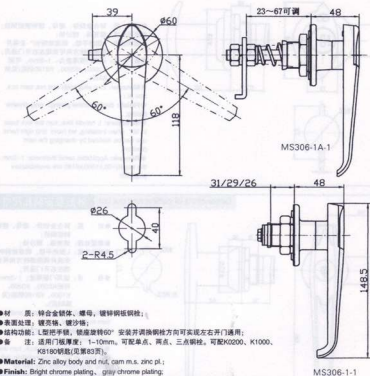

- 材 质: 锌合金本体, 螺母, 镀锌钢板锁芯;
- 表面处理: 硬铬镀, 磨砂;
- 结构功能: L型把手, 锁座旋转90° 安装并调整锁轴方向可实现左右开门通用;
- 备 注: 适用门板厚度: 1-10mm, 可配单点、两点、三点锁芯, 可配K0200, K1000, K8180锁匙(见第83页);
- Material: Zinc alloy body and nut, cam m.s.s. zinc pl.;
- Finish: Bright chrome plating, gray chrome plating;
- Structure: L handle lock, turn the lock base to 90° when installing, left hand and right hand use can be realized by changing the cam position;
- Remark: Applicable panel thickness: 1-10mm, single-point, two-point and three-point cam are available, the key K0200, K1000, K8180 are available(see page 83).

专利号(Patent No): 99323456.9



外形及安装孔尺寸 | Dimensions of outline and cut out

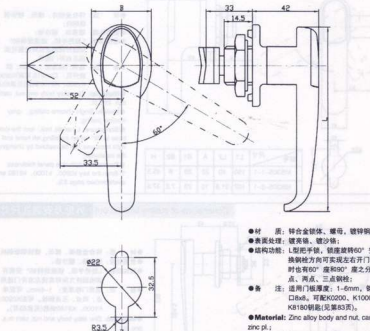

- 材 质: 锌合金本体, 螺母, 镀锌钢板锁芯
- 表面处理: 硬铬镀, 磨砂;
- 结构功能: L型把手, 锁座旋转90° 安装并调整锁轴方向可实现左右开门通用。对应有0° 和90° 之分, 分一点、两点、三点锁芯;
- 备 注: 适用门板厚度: 1-6mm, 铜锁开C888, 可配K0200, K1000, K8180锁匙(见第83页);
- Material: Zinc alloy body and nut, cam m.s.s. zinc pl.;
- Finish: Bright chrome plating, gray chrome plating;
- Structure: L handle lock, turn the lock base to 90° when installing, left hand and right hand use can be realized by changing the cam position, single-point, two-point and three-point cam are available;
- Remark: Applicable panel thickness: 1-6mm, the key K0200, K1000, K8180 are available(see page 83).

型号	尺寸	L	B
MS306-1-1	120	36	
MS306-2-1	102	33	

(型号为MS403-1尺寸) **Dimensions of outline and cut out 外形及安装孔尺寸**

- 材 质: 锌合金壳体、螺母, 镀锌钢板面板, 镀锌铜锁芯;
- 表面处理: 镀锌镍;
- 结构功能: 圆形平面转舌锁, 调换锁轴方向可实现左右开门通用;
- 备 注: 适用门板厚度: 1-10mm, 可配K0400、K0700、K1000、K8180锁匙(见第83页);
- Material: Zinc alloy body and nut, stainless steel face plate cover, cam m.s. zinc pl.;
- Finish: White zinc plating;
- Structure: Cam lock, left hand and right hand use can be realized by changing the cam position;
- Remark: Applicable panel thickness: 1-10mm, the key K0400、K0700、K1000、K8180 are available (see page 83).



Dimensions of outline and cut out 外形及安装孔尺寸

- 材 质: PA-66把手, 锌合金壳体、螺母, 镀锌铜锁芯;
- 表面处理: 镀锌镍;
- 结构功能: L型把手, 调换锁轴方向可实现左右开门通用;
- 备 注: 适用门板厚度: 1-7mm;
- Material: PA-66 handle, zinc alloy body and nut, cam m.s. zinc pl.;
- Finish: White zinc plating;
- Structure: L handle lock, left hand and right hand use can be realized by changing the cam position;
- Remark: Applicable panel thickness: 1-7mm.



Dimensions of outline and cut out 外形及安装孔尺寸

型号	尺寸	L1	H1	±1
MS407-1	35	24	27	
MS407-2	29	18	23	

- 材 质: 锌合金壳体、螺母, 镀锌铜锁芯;
- 表面处理: 喷光金属、镀锌镍、镀锌铬;
- 结构功能: 圆形平面转舌锁, 调换锁轴方向可实现左右开门通用, 锁轴开孔: □8x6;
- 备 注: 适用门板厚度: 1-8mm, 可配K0600、K0200、K1000、K8181锁匙(见第80页);
- Material: Zinc alloy body and nut, cam m.s. zinc pl.;
- Finish: Black powder coated, bright chrome plating, gray chrome plating;
- Structure: Cam lock, left hand and right hand use can be realized by changing the cam position;
- Remark: Applicable panel thickness: 1-8mm, the key K0600、K0200、K1000、K8180 are available (see page 80).



Dimensions of outline and cut out 外形及安装孔尺寸

型号	尺寸	L1	L2	L3	B1	H1	±1
MS408-1-1	50	32.5	28	20	18.5	22	
MS408-2-1	34	27	27	16.5	20	18.5	
MS408-3-1	32	21	24	14.2	14	16	

- 材 质: 锌合金壳体、螺母, 镀锌铜锁芯;
- 表面处理: 喷光金属、镀锌镍、镀锌铬;
- 结构功能: 翼形平面转舌锁, 调换锁轴方向可实现左右开门通用, 锁轴开孔: □8x8, 用钥匙转动锁芯180°后, 转动半圈即可打开门;
- 备 注: 适用门板厚度: 1-6mm, 可配K0333、K1000、K8180锁匙(见第83页);
- Material: Zinc alloy body and nut, cam m.s. zinc pl.;
- Finish: Black powder coated, gray chrome plating;
- Structure: Wing knob lock, left hand and right hand use can be realized by changing the cam position, the door can be opened by turning the handle when turning the insert to 180°;
- Remark: Applicable panel thickness: 1-6mm, the key K0333、K1000、K8180 are available (see page 83).





MS409-1

MS409-2

外形及安装孔尺寸 Dimensions of outline and cut out

●材 质: 锌合金壳体, 镀锌钢板锁柱;
 ●表面处理: 镀锌, 镀锌, 镀锌;
 ●结构功能: 圆形平钥匙, 调换锁柱方向可
 实现左右开门通用;
 ●备 注: 适用门框厚度: 1-6mm, 专用率
 2500把。
 ●Material: Zinc alloy body, cam m.s. zinc pl;
 ●Finish: Bright chrome plating, gray chrome
 plating, black powder coated;
 ●Structure: Cam lock, left hand and right hand
 use can be realized by changing the cam position;
 ●Remark: Applicable panel thickness: 1-6mm.
 2500 key combinations available.



MS410

K0100

外形及安装孔尺寸 Dimensions of outline and cut out

●材 质: 锌合金壳体, 镀锌钢板锁柱;
 ●表面处理: 镀锌, 镀锌, 镀锌;
 ●结构功能: 半圆特字键, 调换锁柱方向可实
 现左右开门通用, 锁芯旋转90°; 钢
 板开孔: □BxR;
 ●备 注: 适用门框厚度: 1-6mm, 可配K0100,
 K1000, K4180钥匙(见第83页)。
 ●Material: Zinc alloy body and nut, cam m.s.
 zinc pl;
 ●Finish: Bright chrome plating, gray chrome
 plating, black powder coated;
 ●Structure: Cam lock, left hand and right hand
 use can be realized by changing the cam position;
 ●Remark: Applicable panel thickness: 1-6mm;
 the key K0100, K1000, K4180 are available(see
 page 83).



MS412

外形及安装孔尺寸 Dimensions of outline and cut out

●材 质: 锌合金壳体, 镀锌钢板锁柱;
 ●表面处理: 镀锌, 镀锌, 镀锌;
 ●结构功能: 拉手式圆筒锁, 调换锁柱位置可
 实现左右开门通用, 钢板
 开孔: □BxR;
 ●备 注: 适用门框厚度: 1-20mm。
 ●Material: Zinc alloy body and nut, cam
 m.s. zinc pl;
 ●Finish: Nickel plating, bright chrome plating,
 gray chrome plating;
 ●Structure: Handle lock, left hand and right
 hand use can be realized by changing the lock-
 tions and cam position;

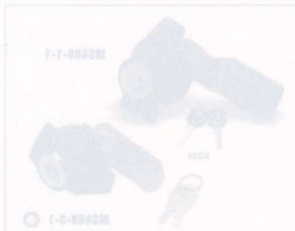

1-C-8842M

●材 质: 锌合金壳体, 镀锌钢板锁柱;
 ●表面处理: 镀锌, 镀锌, 镀锌;
 ●结构功能: 拉手式圆筒锁, 调换锁柱位置可
 实现左右开门通用, 钢板
 开孔: □BxR;
 ●备 注: 适用门框厚度: 1-20mm。
 ●Material: Zinc alloy body and nut, cam
 m.s. zinc pl;
 ●Finish: Nickel plating, bright chrome plating,
 gray chrome plating;
 ●Structure: Handle lock, left hand and right
 hand use can be realized by changing the lock-
 tions and cam position;

Dimensions of outline and cut out 外形及安装孔尺寸

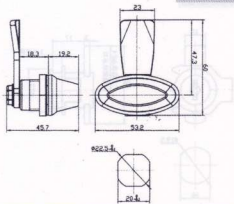

- 材 质: 锌合金壳体, PA-6旋钮, 镀锌钢板锁体
- 结构功能: 手置特舌锁, 调换锁芯方向可实现左右开门通用, 钥匙开孔: $\varnothing 20.4$
- 备 注: 适用门板厚度: 1-6mm.
- Material: Zinc alloy body, PA-6 knob, cam m.s. zinc pl.
- Structure: Cam lock, left hand and right hand use can be realized by changing the cam position;
- Remark: Applicable panel thickness: 1-6mm.



MS414

Dimensions of outline and cut out 外形及安装孔尺寸

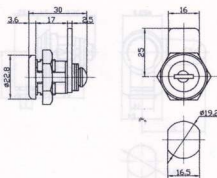

- 材 质: 锌合金壳体, 螺母, 镀锌钢板锁体;
- 表面处理: 镀锌板, 镀锌板, 喷光无漆;
- 结构功能: 小匙形手置特舌锁, 调换锁芯方向可实现左右开门通用, 钥匙开孔: $\varnothing 16.5$
- 备 注: 适用门板厚度: 1-6mm, 可配K0100, K1000, K8180锁芯(见第83页).
- Material: Zinc alloy body and nut, cam m.s. zinc pl.
- Finish: Gray chrome plating, bright chrome plating, black powder coated;
- Structure: Cam lock, left hand and right hand use can be realized by changing the cam position;
- Remark: Applicable panel thickness: 1-6mm, the key K0100, K1000, K8180 are available (see page 83).



K0100

MS415

Dimensions of outline and cut out 外形及安装孔尺寸

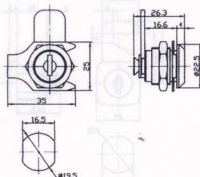

- 材 质: 锌合金壳体, 螺母, 镀锌钢板锁体;
- 表面处理: 镀锌板, 镀锌板, 喷光无漆;
- 结构功能: 小匙形手置特舌锁, 调换锁芯方向可实现左右开门通用, 钥匙开孔: $\varnothing 16.5$
- 备 注: 适用门板厚度: 1-2mm.
- Material: Zinc alloy body and nut, cam m.s. zinc pl.
- Finish: Gray chrome plating, bright chrome plating, black powder coated;
- Structure: Cam lock, left hand and right hand use can be realized by changing the cam position;
- Remark: Applicable panel thickness: 1-2mm.

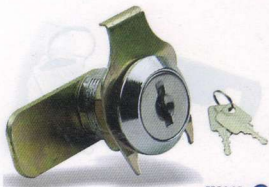

MS416

Dimensions of outline and cut out 外形及安装孔尺寸

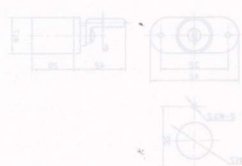

- 材 质: 锌合金壳体, 螺母, 镀锌钢板锁体;
- 表面处理: 镀锌板, 镀锌板, 喷光无漆;
- 结构功能: 小匙形手置特舌锁, 调换锁芯方向可实现左右开门通用, 钥匙开孔: $\varnothing 16.5$
- 备 注: 适用门板厚度: 1-2mm.
- Material: Zinc alloy body and nut, cam m.s. zinc pl.
- Finish: Gray chrome plating, bright chrome plating, black powder coated;
- Structure: Cam lock, left hand and right hand use can be realized by changing the cam position;
- Remark: Applicable panel thickness: 1-2mm.



MS417



MS417

外形及安装孔尺寸 Dimensions of outline and cut out

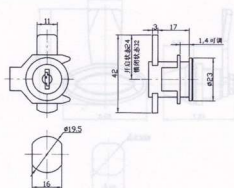

- 材料: 锌合金锁体, 镀锌钢板锁芯;
- 表面处理: 镀锌板, 镀锌板;
- 结构功能: 圆形平面锁芯, 更换锁芯方向可实现左右开门通用;
- 备注: 适用门板厚度: 1-6mm;
- Material: Zinc alloy body/cam m.s.; zinc pl.;
- Finish: Bright chrome plating, gray chrome plating;
- Structure: Cam lock, left hand and right hand use can be realized by changing the cam position;
- Remark: applicable panel thickness: 1-6mm.



MS418

外形及安装孔尺寸 Dimensions of outline and cut out

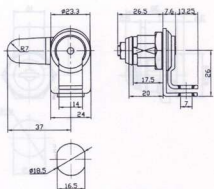

- 材料: 锌合金锁体, 镀锌钢板锁芯;
- 表面处理: 镀锌板, 镀锌板;
- 结构功能: L型锁, 可装锁芯位置, 请按照锁芯方向可实现左右开门通用;
- 备注: 适用门板厚度: 1-10mm;
- Material: Zinc alloy body, cam m.s.; zinc pl.;
- Finish: Bright chrome plating, gray chrome plating;
- Structure: L style lock, can be installed with padlock, left hand and right hand use can be realized by changing the cam position;
- Remark: Applicable panel thickness: 1-10mm.



MS419

外形及安装孔尺寸 Dimensions of outline and cut out

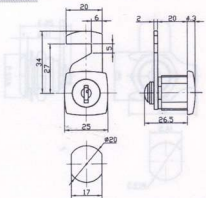

- 材料: 锌合金锁体, 镀锌钢板锁芯;
- 表面处理: 镀锌板, 镀锌板;
- 结构功能: 四方扁平锁芯, 更换锁芯方向可实现左右开门通用;
- Material: Zinc alloy body, cam m.s.; zinc pl.;
- Finish: Gray chrome plating, bright chrome plating;
- Structure: Square style lock, left hand and right hand use can be realized by changing the cam position;



MS420

外形及安装孔尺寸 Dimensions of outline and cut out

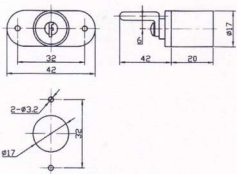

- 材料: 锌合金锁体;
- 表面处理: 镀锌板, 镀锌板;
- 结构功能: 圆形平面锁芯;
- 备注: 适用门板厚度: 1-20mm;
- Material: Zinc alloy body;
- Finish: Gray chrome plating, bright chrome plating;
- Structure: Desk lock, for drawer;
- Remark: Applicable panel thickness: 1-20mm.



MS-A-403

外形及安装孔尺寸 Dimensions of outline and cut out

- **材 质:** 锌合金锁体、螺母、正钢锁芯、镀锌钢锁芯
- **表面处理:** 喷沙镀铬、镀镍铬、镀锌铬
- **结构功能:** 圆形半圆锁, 带防尘盖, 调换锁体方向可实现在右开门锁用, 锁体开孔: $\varnothing 7 \times 7$
- **备 注:** 适用门框厚度: 1-5mm, 专用螺16把。
- **Material:** Zinc alloy body and nut, brass insert, cam m.s. zinc pl.
- **Finish:** Matt gray chrome plating, bright chrome plating.
- **Structure:** Cam lock, with dust cover, left hand and right hand use can be realized by changing the cam position.
- **Remark:** Applicable panel thickness: 1-5mm, 16 key combinations available.

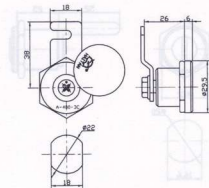

MS-A-404

K7010

外形及安装孔尺寸 Dimensions of outline and cut out

- **材 质:** 锌合金锁体、螺母、钢芯、镀锌钢锁芯
- **表面处理:** 喷沙镀铬、镀镍铬、镀锌铬
- **结构功能:** 菱形半圆锁, 带防尘盖, 调换锁体方向可实现在右开门锁用
- **备 注:** 适用门框厚度: 1-5mm, 可配K7010, K7030, K7040, K7050锁匙(见页83)。
- **Material:** Zinc alloy body, nut and key, cam m.s. zinc pl.
- **Finish:** Matt gray chrome plating, bright chrome plating, grey chrome plating.
- **Structure:** Cam lock, with dust cover, left hand and right hand use can be realized by changing the cam position.
- **Remark:** Applicable panel thickness: 1-5mm, the key K7010, K7030, K7040, K7050 are available (see page 83).

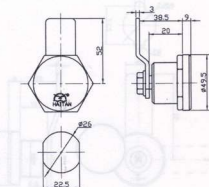

MS460-1

K0540

外形及安装孔尺寸 Dimensions of outline and cut out

- **材 质:** 锌合金锁体、镀锌钢锁芯、压板、传动架
- **表面处理:** 喷沙镀铬、镀镍铬、喷光亮黑、喷沙镀铬
- **结构功能:** 按钮式凸轮传动半圆锁, 传动体与锁体可单独分离, 调换定位位置和功能锁体方向可实现在左开门锁用, 传动架耐压耐用, 具有防水功能
- **备 注:** 适用门框厚度: 1-4.5mm, 铜棒开孔: $\varnothing 16$, 可配K0540, K1000, K8180锁匙(见页83)。
- **Material:** Zinc alloy body and shaft, cam, fixing material and rod m.s. zinc pl.
- **Finish:** Gray chrome plating, bright chrome plating, black powder coated, matt black powder coated.
- **Structure:** Push button rod control lock, the rod control can be singly separated from lock body, left hand and right hand can be realized by changing the locations and cam position, the rod control can be used as fixing material, with sealed and waterproof functions.
- **Remark:** Applicable panel thickness: 1-4.5mm, the key K0540, K1000, K8180 are available (see page 83).

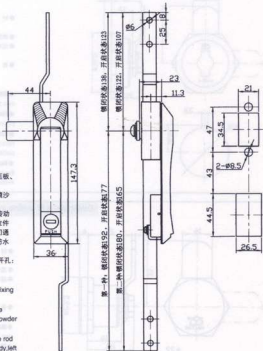



外形及安装孔尺寸 Dimensions of outline and cut out

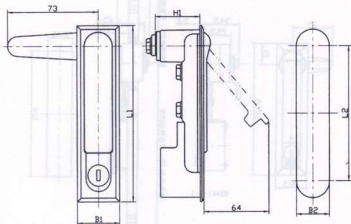

- 材 质: 锌合金壳体、转轴、镀锌钢板钢板;
- 表面处理: 镀锌板、镀黄铜、抛光亮黑、磨砂钛黑;
- 结构功能: 按按钮式半锁钮, 调换定位位置可实现左右开门通用, 具密封防水功能, 可配单点、两点、三点锁栓;
- 备 注: 通用门框厚度: 1-10mm, MS480-2-1外形有方圆之分, 同时也有圆孔和斜合金锁壳之分, 铜柱开孔: $\varnothing 10 \times 10$, 可配K0200, K0600, K1000, K8180, K8070锁匙(见页83);
- Material: Zinc alloy body and shaft, cam m.s., zinc pl.
- Finish: Gray chrome plating, bright chrome plating, black powder coated, matt black powder coated;
- Structure: Push button lock, left hand and right hand use can be realized by changing the locations, with sealed and waterproof functions, single-point, two-point and three-point cam are available;
- Remark: Applicable panel thickness: 1-10mm, the key K0200, K0600, K1000, K8180, K8070 are available(see page 83).

型号	尺寸	L1	L2	B1	B2	H1
MS480-1-1		158	120.5	40	32	37
MS480-1-2		140	108	34	26	34



外形及安装孔尺寸 Dimensions of outline and cut out

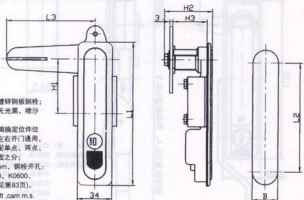

- 材 质: 锌合金壳体、转轴、镀锌钢板钢板;
- 表面处理: 镀锌板、镀黄铜、抛光亮黑、磨砂钛黑;
- 结构功能: 按钮式半锁钮, 调换定位位置可实现左右开门通用, 具密封防水功能, 可配单点、两点、三点锁栓, 外形有方圆之分;
- 备 注: 通用门框厚度: 1-8mm, 铜柱开孔: $\varnothing 10 \times 10$, 可配K0200, K0600, K1000, K8180锁匙(见页83);
- Material: Zinc alloy body and shaft cam m.s., zinc pl.
- Finish: Gray chrome plating, bright chrome plating, black powder coated, matt black powder coated;
- Structure: Push button lock, left hand and right hand use can be realized by changing the locations, with sealed and waterproof functions, single-point, two-point and three-point cam are available, available in both square and round appearance;
- Remark: Applicable panel thickness: 1-8mm, the key K0200, K0600, K1000, K8180 are available(see page 83);

型号	尺寸	L1	L2	L3	H1	H2	H3	B
MS481-1-1		142	108	88	54	46	34	26.5
MS481-2-1		124	88	73	44	41	28	26



外形及安装孔尺寸 Dimensions of outline and cut out

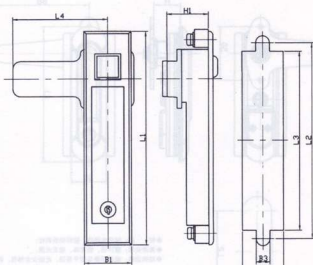

- 材 质: 锌合金壳体, 镀锌钢板钢板;
- 表面处理: 硬铬漆, 喷沙漆;
- 结构功能: 按钮弹出式平钥匙, 左右开门通用, 锁芯有左右之分;
- 备 注: 适用门板厚度: 1-4mm;
- Material: Zinc alloy body, cam m.s.s. zinc pl.
- Finish: Single chrome plating, gray chrome plating;
- Structure: Push button lock, both left hand and right hand use, cam position either on the left or on the right;
- Remark: Applicable panel thickness: 1-4mm.

型号	L1	L2	L3	L4	B1	B2	B3	H1
MS501-1-1	140	126	115.5	61.5	31	27	8.5	27
MS501-2-1	105	91.5	79.5	52	27	22.5	7	25

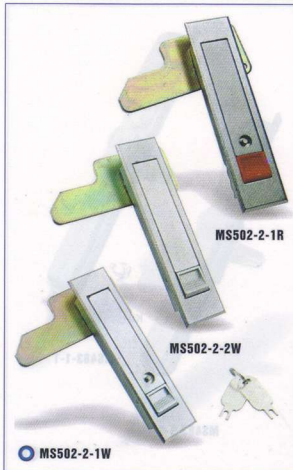

外形及安装孔尺寸 Dimensions of outline and cut out

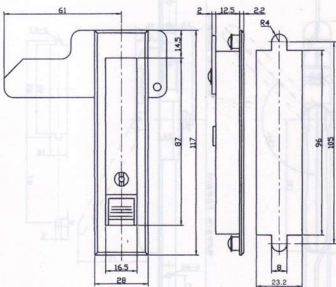

- 材 质: 锌合金壳体, 镀锌钢板钢板;
- 表面处理: 喷沙漆;
- 结构功能: 按钮弹出式平钥匙, 调整锁芯方向可实现左右开门通用;
- 备 注: 适用门板厚度: 1-4mm;
- Material: Zinc alloy body, cam m.s.s. zinc pl.;
- Finish: Multi gray chrome plating;
- Structure: Push button lock, left hand and right hand use can be realized by changing the cam position;
- Remark: applicable panel thickness: 1-4mm.

Dimensions of outline and cut out 外形及安装孔尺寸

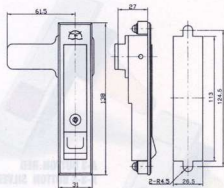

- 材 质: 锌合金壳体, 镀锌钢板钢板;
- 表面处理: 镀锌镀铬;
- 结构功能: 按按钮出式平开锁, 左右开门通用, 钢板有左右之分;
- 备 注: 适用门板厚度: 1-4mm.
- Material: Zinc alloy body, cam m.s. zinc pl.
- Finish: Matt gray chrome plating.
- Structure: Push button lock, both left hand and right hand use, cam position either on the left or on the right;
- Remark: Applicable panel thickness: 1-4mm.



MS502-1

Dimensions of outline and cut out 外形及安装孔尺寸

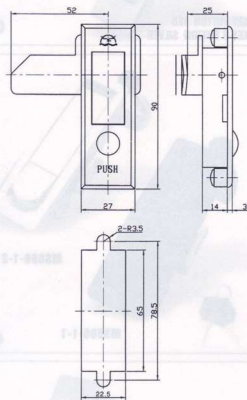

- 材 质: 锌合金壳体, 镀锌钢板钢板;
- 表面处理: 镀锌镀铬, 镀锌铬;
- 结构功能: 按按钮出式平开锁, 左右开门通用, 钢板有左右之分;
- 备 注: 适用门板厚度: 1-4mm.
- Material: Zinc alloy body, cam m.s. zinc pl.
- Finish: Gray chrome plating, bright chrome plating;
- Structure: Push button lock, both left hand and right hand use, cam position either on the left or on the right;
- Remark: applicable panel thickness: 1-4mm.



MS503-1-2



MS503-1-2A

Dimensions of outline and cut out 外形及安装孔尺寸

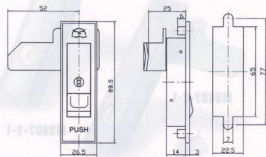

- 材 质: 锌合金壳体, 镀锌钢板钢板;
- 表面处理: 镀锌镀铬, 镀锌铬;
- 结构功能: 按按钮出式平开锁, 左右开门通用, 钢板有左右之分;
- 备 注: 适用门板厚度: 1-4mm.
- Material: Zinc alloy body, cam m.s. zinc pl.
- Finish: Matt gray chrome plating, bright chrome plating;
- Structure: Push button lock, both left hand and right hand use, cam position either on the left or on the right;
- Remark: applicable panel thickness: 1-4mm.



MS503-1

Dimensions of outline and cut out 外形及安装孔尺寸

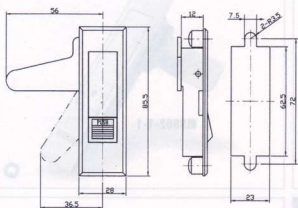

- **材 质:** 锌合金壳体, 镀锌钢板衬板;
- **表面处理:** 喷沙镀铬、喷沙铬、喷光亮黑、
- **结构功能:** 按钮弹出式平面锁, 调整按钮方向可实现左右开门锁闭;
- **备 注:** 适用门板厚度: 1-4mm;
- **Material:** Zinc alloy body, cam m.s. zinc pl.
- **Finish:** Matt gray chrome plating, gray chrome plating, black powder coated;
- **Structure:** Push button lock, left hand and right hand use can be realized by changing the cam position;
- **Remarks:** Applicable panel thickness: 1-4mm

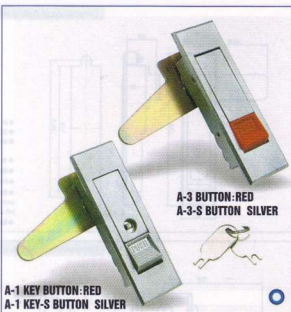

A-3 BUTTON: RED
A-3-S BUTTON: SILVER

A-1 KEY BUTTON: RED
A-1 KEY-S BUTTON: SILVER

Dimensions of outline and cut out 外形及安装孔尺寸

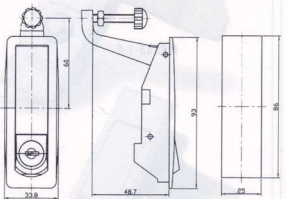

- **材 质:** 锌合金壳体, 镀锌钢板衬板;
- **表面处理:** 喷光亮黑、喷沙铬黑、喷沙铬、镀铬(镍);
- **结构功能:** 按钮弹出式平面锁, 可调节止口高度, 弹起把手即可打开柜门;
- **Material:** Zinc alloy body, cam m.s. zinc pl.
- **Finish:** Black powder coated, matt black powder coated, gray chrome plating, bright chrome plating;
- **Structure:** Push button lock, adjustable stopper height, the handle pops up to open the cabinet door.



MS606-1-2

MS606-1-1

Dimensions of outline and cut out 外形及安装孔尺寸

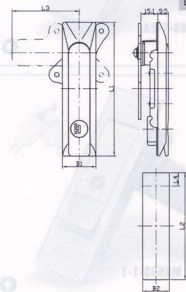

- **材 质:** 锌合金壳体, 镀锌钢板衬板;
- **表面处理:** 喷沙铬、喷光黑、喷沙铬黑;
- **结构功能:** 平面锁, 调整定位位置和锁棒方向可实现左右开门, 具有防拆功能, 可配单点、两点、三点锁;
- **备 注:** 适用门板厚度: 1-7mm, 锁棒开孔: MS607-1-1, MS607-2-1, MS607-3-1 已标配, 可配K0200, K1000, K8180 铜匙(见页83);
- **Material:** Zinc alloy body, cam m.s. zinc pl.
- **Finish:** Gray chrome plating, bright chrome plating, black powder coated, matt black powder coated;
- **Structure:** Handle lock, left hand and right hand use can be realized by changing the locations, with sealed and waterproof functions. Single-point, two-point and three-point cam are available(see page 83);

型号	尺寸	L1	L2	L3	L4	B1	B2
MS607-1-1		147	117	72	13.5	33	27
MS607-2-1		121	96	65	12	30	24
MS607-3-1		88	63	65	12	30	24



MS607-2-1

MS607-1-1

K0200

外形及安装孔尺寸 Dimensions of outline and cut out



MS705-3

- **材 质:** 塑料壳体、螺母、钥匙;
- **表面处理:** 黑色、乳白色;
- **结构功能:** 方形半圆球, 左右开门通用, 具有防水功能。
- **备 注:** 适用门板厚度: 1.5-2mm, 可配 K7010、K7020、K7040、K7050 型 (见页 83)。
- **Material:** Plastic body, nut and key;
- **Surface color:** Black, other colors on request;
- **Structure:** Both left hand and right hand use, with waterproof function;
- **Remark:** Applicable panel thickness: 1.5-2mm, the key K7010, K7020, K7040, K7050 are available (see page 83).

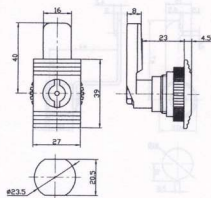

外形及安装孔尺寸 Dimensions of outline and cut out



MS706

- **材 质:** 锌合金壳体, 镀锌铜镀铬;
- **表面处理:** 镀亮铬、镀沙铬;
- **结构功能:** 密封防水半圆球, 左右开门通用;
- **备 注:** 适用门板厚度: 1-3mm, 铜镀铬开孔: $\phi 18.8$ 。
- **Material:** Zinc alloy body, cam m.s. zinc pl.
- **Finish:** Bright chrome plating, gray chrome plating;
- **Structure:** Lock with sealed and waterproof functions, both left hand and right hand use;
- **Remark:** Applicable panel thickness: 1-3mm.

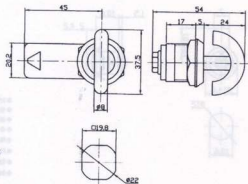

外形及安装孔尺寸 Dimensions of outline and cut out



MS707

- **材 质:** 锌合金壳体, 铜镀铬铜镀铬, 镀锌铜镀铬;
- **表面处理:** 镀亮铬、镀沙铬、纯无光黑;
- **结构功能:** 左右开门通用, 可调节门板锁紧度;
- **备 注:** 适用门板厚度: 1-5mm, 铜镀铬开孔: $\phi 22$ 。
- **Material:** Zinc alloy body, inset m.s. zinc pl.
- **Finish:** Bright chrome plating, gray chrome plating, black powder coated;
- **Structure:** Both left hand and right hand use, adjustable cam;
- **Remark:** Applicable panel thickness: 1-5mm.

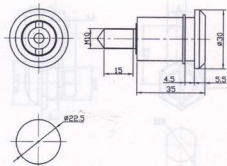

外形及安装孔尺寸 Dimensions of outline and cut out



MS708-1

- **材 质:** 锌合金壳体, 铜镀铬, 镀锌铜镀铬, 镀锌铜镀铬;
- **表面处理:** 镀亮铬、镀沙铬、纯无光黑;
- **结构功能:** 圆扁半圆球, 左右开门通用;
- **备 注:** 适用门板厚度: 1-4mm。
- **Material:** Zinc alloy body and key/cam and nut m.s. zinc pl.
- **Finish:** Gray chrome plating, bright chrome plating, black powder coated;
- **Structure:** Both left hand and right hand use;
- **Remark:** Applicable panel thickness: 1-4mm.

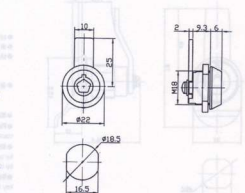



MS711-2-1

外形及安装孔尺寸 Dimensions of outline and cut out

- 材料 质: 锌合金钢球, PA-6手柄, 镀锌钢板衬板;
- 表面处理: 喷光亮黑;
- 结构功能: 密封防水半圆锁, 左右开门通用;
- 备注: 适用门框厚度: 1-8mm, 锁芯开孔: 12x30;
- Material: Zinc alloy body, PA-6 handle, cam m.s.zinc pl.;
- Finish: Black powder coated;
- Structure: With sealed and waterproof functions, both left hand and right hand use;
- Remark: Applicable panel thickness: 1-8mm.

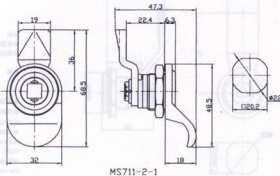

MS711-2-1

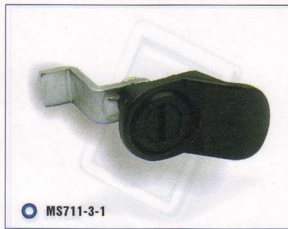

MS711-3-1

外形及安装孔尺寸 Dimensions of outline and cut out

- 材料 质: 锌合金钢球, PA-6手柄, 镀锌钢板衬板;
- 表面处理: 喷光亮黑;
- 结构功能: 密封防水半圆锁, 左右开门通用;
- 备注: 适用门框厚度: 1-4mm, 锁芯开孔: 12x26x2;
- Material: Zinc alloy body, PA-6 handle, cam m.s.zinc pl.;
- Finish: Black powder coated;
- Structure: With sealed and waterproof functions, both left hand and right hand use;
- Remark: Applicable panel thickness: 1-4mm.

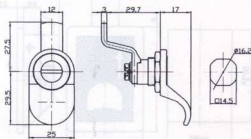

MS711-3-1

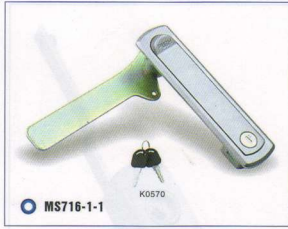

MS716-1-1

外形及安装孔尺寸 Dimensions of outline and cut out

- 材料 质: 锌合金钢球, 铁轴, 镀锌钢板衬板;
- 表面处理: 喷光亮黑, 喷沙, 喷灰;
- 结构功能: 按按钮式半圆锁, 调换定位位置, 具有密封防水功能, 可配单点, 两点, 三点锁芯;
- 备注: 适用门框厚度: 1-6mm, 可配K1000, K1000, K06180锁芯(见第83页);
- Material: Zinc alloy body and shaft, cam m.s.zinc pl.;
- Finish: Bright chrome plating, gray chrome plating, black powder coated, matt black powder coated;
- Structure: Push button lock, left hand and right hand use can be realized by changing the locations and cam position with sealed and waterproof functions; single-point, two-point and three-point cam are available;
- Remark: Applicable panel thickness: 1-6mm, The key K1000, K1000, K06180 are available (see page 83).

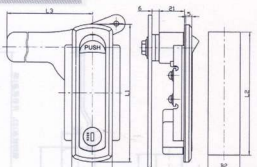

型号	尺寸	L1	L2	L3	B1	B2
MS716-1-1		155	141	140	38	30
MS716-2-1		115	103	100	34	27



MS717

外形及安装孔尺寸 Dimensions of outline and cut out

- 材料 质: 锌合金钢球, 螺母, 铁轴, 镀锌钢板衬板;
- 表面处理: 喷沙, 镀锌镍, 喷光亮黑;
- 结构功能: 密封半圆锁, 左右开门通用, 带防用螺母盖;
- 备注: 适用门框厚度: 1-10mm, 可配K7010, K7030, K7040, K7050锁芯(见第83页);
- Material: Zinc alloy body/nut and key, cam m.s.zinc pl.;
- Finish: Bright chrome plating, gray chrome plating, black powder coated;
- Structure: Both left hand and right hand use, with weather cover;
- Remark: Applicable panel thickness: 1-10mm, the key K7010, K7030, K7040, K7050 are available(see page 83).

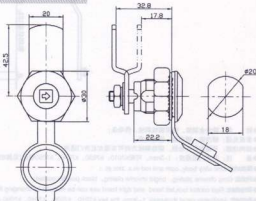

专利号(Patent No): 03368834.6



MS732-1-1

外形及安装孔尺寸 Dimensions of outline and cut out

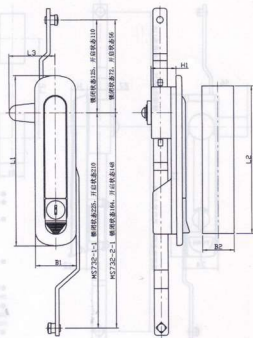

- 材 质: 锌合金箱体、转轴、镀锌铜板锁芯
- 表面处理: 镀锌板、镀锌板、磷化光面、磷化雾面
- 结构功能: 以按钮式平面作动器, 调整定位件位置及锁轴方向可实现左右开门通用, 可配单点、两点、三点锁芯, 锁轴开孔: C轴孔
- 备 注: 适用门框厚度: 1-4mm, 可配 K0200、K0550、K1000、K8180锁芯(见第83页)
- Material: Zinc alloy body and shaft, cam m.s. zinc plating
- Finish: Bright chrome plating, gray chrome plating, black powder coated, matt black powder coated
- Structure: Push button rod control lock, left hand and right hand use can be realized by changing the locations and cam position, single-point, two-point and three-point cam are available
- Remark: Applicable panel thickness: 1-4mm, the key K0200, K0550, K1000, K8180 are available (see page 83)

型 号	L1	L2	L3	B1	B2	H1
MS732-1-1	148	128	46	33	28.5	27
MS732-2-1	130	113	35	31	24.5	19

外形及安装孔尺寸 Dimensions of outline and cut out

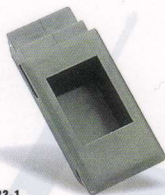

MS733-1

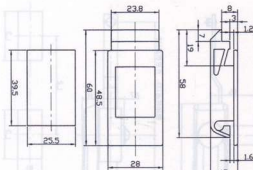

- 材 质: ABS
- 表面处理: 灰色、黑色、白色
- 结构功能: 内置塑料门框, 带有弹簧, 当作用力向右侧时弹簧收缩, 开启柜门, 离开时复位按钮柜门
- 备 注: 适用门框厚度: 1-1.2mm
- Material: ABS
- Surface color: Gray, black, white
- Structure: Simple plastic lock, with spring when force back, the spring allows to open the cabinet door, the spring resets to lock the door
- Remark: Applicable panel thickness: 1-1.2mm

外形及安装孔尺寸 Dimensions of outline and cut out



MS733-2

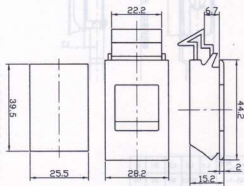

- 材 质: ABS
- 表面处理: 灰色、黑色、白色
- 结构功能: 内置塑料门框, 带有弹簧, 当作用力向右侧时弹簧收缩, 开启柜门, 离开时复位按钮柜门
- 备 注: 适用门框厚度: 1-1.2mm
- Material: ABS
- Surface color: Gray, black, white
- Structure: Simple plastic lock, with spring when force back, the spring allows to open the cabinet door, the spring resets to lock the door

Dimensions of outline and cut out 外形及安裝孔尺寸

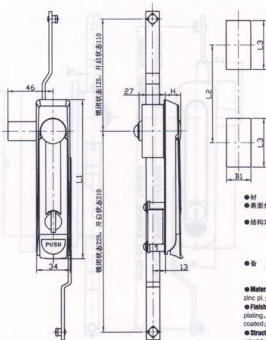

型號	尺寸	L1	L2	L3	B1	B2	H
MS741-1-1	162	100.5	50	25	16		
MS741-2-1	136	74	49.5	24.5	18		

●材 質：鋅合金鎖體、轉軸、鑲特種銅絲。
 ●表面處理：鍍沙粉、鍍青粉、噴光光澤、噴沙
 底漆。
 ●結構功能：傳動體和鎖體可直插分離，調整
 定位位置和鎖體方向可實現左右
 開門應用，傳動體可作吊裝用，具備
 防斷水功能，可配單點、異點、三
 點鎖鉤，可按需求安裝特製鎖鑰。
 ●備 注：適用於鎖厚度：1-4mm，鎖體開
 孔：□8x6，可配K0570、K1000、
 K3180鎖匙（見第83頁）。
 ●Material: Zinc alloy body and shaft, cam m.s.
 zinc plating.
 ●Finish: Gray chrome plating, bright chrome
 plating, black powder coated, matt black powder
 coated.
 ●Structure: The rod control can be singly separ-
 ated from lock body with hand and right hand use
 can be realized by changing the locations, the
 rod control can be used as fixing material, with
 sealed and waterproof functions, single-point,
 two-point and three-point cam are available,
 can be installed with padlock.
 ●Remarks: Applicable panel thickness:
 1-4mm, the key K0570, K1000, K3180 are
 available(see page 83).



Dimensions of outline and cut out 外形及安裝孔尺寸

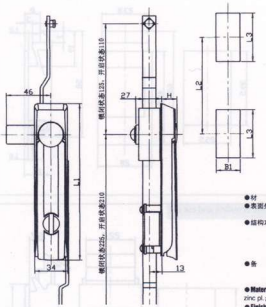

型號	尺寸	L1	L2	L3	B1	B2	H
MS742-1-1	162	100.5	50	25	16		
MS742-2-1	136	74	49.5	24.5	18		

●材 質：鋅合金鎖體、轉軸、鑲特種銅絲。
 ●表面處理：鍍沙粉、鍍青粉、噴光光澤、噴沙
 底漆。
 ●結構功能：傳動體和鎖體可直插分離，調整
 定位位置和鎖體方向可實現左右
 開門應用，傳動體可作吊裝用，具備
 防斷水功能，可配單點、異點、三
 點鎖鉤，可按需求安裝特製鎖鑰。
 ●備 注：適用於鎖厚度：1-4mm，鎖鉤開
 孔：□8x6，可配K0570、K1000、
 K3180鎖匙（見第83頁）。
 ●Material: Zinc alloy body and shaft, cam m.s.
 zinc plating.
 ●Finish: Gray chrome plating, bright chrome
 plating, black powder coated, matt black powder
 coated.
 ●Structure: The rod control can be singly separ-
 ated from lock body with hand and right hand use
 can be realized by changing the locations, the
 rod control can be used as fixing material, with
 sealed and waterproof functions, single-point,
 two-point and three-point cam are available,
 can be installed with padlock.
 ●Remarks: Applicable panel thickness:
 1-4mm, the key K0570, K1000, K3180 are
 available(see page 83).





MS743-1-1 K0570

外形及安装孔尺寸 Dimensions of outline and cut out

- 材 质: 锌合金壳体, 镀锌钢板钢板;
- 表面处理: 镀锌, 喷美锈, 抛光亮黑, 喷沙纹黑;
- 结构功能: 按钮弹出式平握锁, 调换定位件位置及锁轴方向可实现左右开门通用, 可配单点、两点和三点锁;
- 备 注: 适用门板厚度: 1-4mm, 锁轴开孔: $\varnothing 8$ mm; 可配K0570, K1000, K8180锁芯(见页83);
- Material: Zinc alloy body, cam m.s. zinc pl.;
- Finish: Gray chrome plating, bright chrome plating, black powder coated, matt black powder coated;
- Structure: Push button lock, left hand and right hand use can be realized by changing the locations and cam position, single-point, two-point and three-point cam are available;
- Remarks: Applicable panel thickness: 1-4mm, the key K0570, K1000, K8180 are available(see page 83).

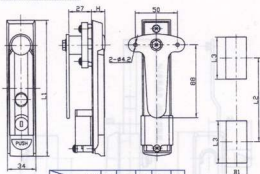

型号	尺寸	L1	L2	L3	B1	B2	H
MS743-1-1	162	100.5	50	25	16		
MS743-2-1	136	74	49.5	24.5	18		



MS744-1-1 K0570

外形及安装孔尺寸 Dimensions of outline and cut out

- 材 质: 锌合金壳体, 镀锌钢板钢板;
- 表面处理: 镀锌, 喷美锈, 抛光亮黑, 喷沙纹黑;
- 结构功能: 平握锁, 锁芯旋转180°, 把平合金轴转动, 可调换定位位置及锁轴方向可实现左右开门通用, 可配单点、两点和三点锁;
- 备 注: 适用门板厚度: 1-4mm, 锁轴开孔: $\varnothing 8$ mm; 可配K0570, K1000, K8180锁芯(见页83);
- Material: Zinc alloy body, cam m.s. zinc pl.;
- Finish: Gray chrome plating, bright chrome plating, black powder coated, matt black powder coated;
- Structure: Push button lock, the handle pops up when turning the insert to 180° left hand and right hand use can be realized by changing the locations and cam position; single-point, two-point and three-point cam are available;
- Remarks: Applicable panel thickness: 1-4mm, the key K0570, K1000, K8180 are available(see page 83).

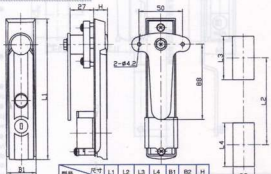

型号	尺寸	L1	L2	L3	L4	B1	B2	H
MS744-1-1	162	100.5	50	50	34	25	16	
MS744-2-1	136	74	49.5	48.5	34	24.5	18	
MS744-3-1	121	88	49.5	34.5	30	24.5	18	



MS751-1-1

MS751-3-1

K0570

外形及安装孔尺寸 Dimensions of outline and cut out

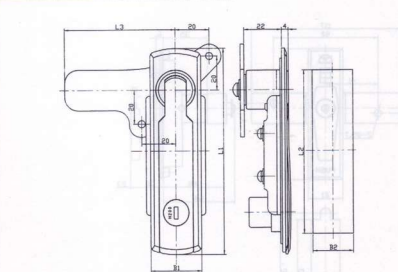

- 材 质: 锌合金壳体, 镀锌钢板钢板;
- 表面处理: 镀锌, 喷美锈, 抛光亮黑;
- 结构功能: 平握锁, 锁芯开孔时手指起握背并转动90°可开门, 调换定位件位置和锁轴方向可实现左右开门通用, 可配单点、两点、三点锁;
- 备 注: 适用门板厚度: 1-6mm, 可配K0570, K1000, K8180锁芯(见页83);
- Material: Zinc alloy body and shaft, cam m.s. zinc pl.;
- Finish: Bright chrome plating, gray chrome plating, black powder coated;
- Structure: The door can be opened by turning the handle to 90° in unlock position, left hand and right hand use can be realized by changing the locations, single-point two-point and three-point cam are available;
- Remarks: Applicable panel thickness: 1-6mm, the key K0570, K1000, K8180 are available(see page 83).

型号	尺寸	L1	L2	L3	B1	B2
MS751-1-1	147	117	72	33	27	
MS751-2-1	121	96	65	30	24	
MS751-3-1	88	63	65	28.5	24	

型号	尺寸	L1	L2	L3	L4	B1	B2	H
MS743-1-1	162	100.5	50	25	16			
MS743-2-1	136	74	49.5	24.5	18			
MS744-1-1	162	100.5	50	50	34	25	16	
MS744-2-1	136	74	49.5	48.5	34	24.5	18	
MS744-3-1	121	88	49.5	34.5	30	24.5	18	

●材 质：锌合金壳体、锌轴、镀锌钢板
 ●表面处理：喷沙漆、镀锌漆、喷光无漆、喷沙钛金
 ●结构功能：单磁锁或双磁锁，深嵌定位件位置和锁杆方向可实现左右开门通用，可配单点、两点、三点锁芯，钢杆开孔：(2x)3.4
 ●备 注：适用门板厚度：1-4mm，可配 K0570、K1000、K8180锁芯(见选型目录)
 ●Material: Zinc alloy body and shaft, cam m.s. zinc pl.
 ●Finish: Bright chrome plating, gray chrome plating, black powder coated, matt black powder coated.
 ●Structure: Push button rod control lockset hand and right hand use can be realized by changing the locations and cam position. single-point, two-point and three-point cam are available.
 ●Remarks: Applicable panel thickness: 1-4mm, the key K0570, K1000, K8180 are available (see page 83).

型号	尺寸	L1	L2
MS761-1-1	158	100	
MS761-2-1	133	75	



●材 质：锌合金壳体、镀锌钢板
 ●表面处理：喷沙漆、镀锌漆、喷光无漆
 ●结构功能：弹出式平盖锁，有单点和三点锁杆之分
 ●备 注：适用门板厚度：1-4mm
 ●Material: Zinc alloy body, cam m.s. zinc pl.
 ●Finish: Gray chrome plating, bright chrome plating, black powder coated.
 ●Structure: Push button lock, either single-point cam or three-point cam.
 ●Remarks: Applicable panel thickness: 1-4mm.

型号	尺寸	L1	L2	L3	B1	B2
MS801-1-1	139	127	115	30.5	26.5	
MS801-2-1	103	94	84	27	23	



Dimensions of outline and cut out 外形及安装孔尺寸

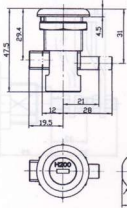

- 材 质: 锌合金壳体、铜芯;
- 表面处理: 镀锌、镀铬、电泳;
- 结构功能: 变式开关程序锁, 锁芯转动180°, 钥匙旋不出壳, 用于高压开关柜上。
- Material: Zinc alloy body and nut;
- Finish: Gray chrome plating, bright chrome plating;
- Structure: Adapted for high voltage cabinets.



MS819

Dimensions of outline and cut out 外形及安装孔尺寸

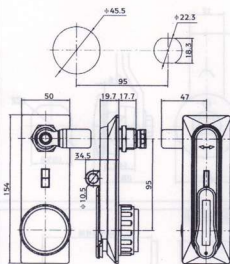

- 材 质: PA-66壳体, 锌合金锁芯、铜芯; 镀锌、镀铬、电泳;
- 表面处理: 黑色, 其它颜色按客户要求;
- 结构功能: 豪华型半圆锁, 异形半圆柱锁芯, 带锁芯防尘盖, 带换锁方向可配两齿或三齿锁芯, 可配两齿、三齿锁芯, 按客户要求可安装防钻锁, 也可安装防钻锁。
- 注 意: 适用门框厚度: 1-8mm, 锁芯开孔: 12mm, 可配K7000、K7010、K7030、K7040、K7050锁芯(见页83页)。
- Material: PA-66 body, zinc alloy insert and key, cam m.s. zinc pl.
- Surface color: Black, other colors on request;
- Structure: Nice appearance, double bit insert, with dust cover, left hand and right hand use can be realized by changing the cam position, two-point, three point cam are available, can be in-stalled with padlock;
- Remark: Applicable panel thickness: 1-8mm, the key K7000, K7010, K7030, K7040, K7050 are available(see page 83).



MS820

Dimensions of outline and cut out 外形及安装孔尺寸

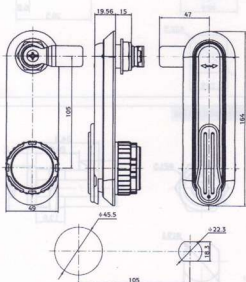

- 材 质: PA-66壳体, 锌合金壳体、铜芯; 镀锌、镀铬、电泳;
- 表面处理: 黑色, 其它颜色按客户要求;
- 结构功能: 豪华型半圆锁, 异形半圆柱锁芯, 带锁芯防尘盖, 带换锁方向可配两齿或三齿锁芯, 可配两齿、三齿锁芯, 按客户要求可安装防钻锁, 也可安装防钻锁。
- 注 意: 适用门框厚度: 1-8mm, 锁芯开孔: 12mm, 可配K7000、K7010、K7030、K7040、K7050锁芯(见页83页)。
- Material: PA-66 body, zinc alloy insert and key, cam m.s. zinc pl.
- Surface color: Black, other colors on request;
- Structure: Nice appearance, double bit insert, with dust cover, left hand and right hand use can be realized by changing the cam position, two-point, three point cam are available, can be installed with padlock;
- Remark: Applicable panel thickness: 1-8mm, the key K7000, K7010, K7030, K7040, K7050 are available(see page 83).



MS821



外形及安装孔尺寸 Dimensions of outline and cut out

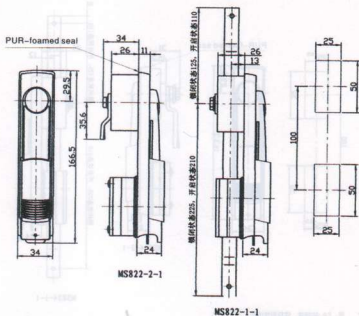

- 材 质: PA-66锁体, 镀锌钢板连杆;
- 表面处理: 沙面漆, 其它颜色可按要求定制;
- 结构功能: 带滑盖的右旋转锁半锁体, 带锁体与锁体可直接分离, 请按照锁体方向可实现左右开门通用, 可配单点、两点、三点锁匙;
- 备 注: 适用门板厚度: 1-8mm, 锁体开孔: □36h, 可配K1010, K7010, K7030, K7040, K7050锁匙(见第83页);
- Material: PA-66 body, rod m.s. zinc pl.
- Surface color: Black, other colors on request;
- Structure: Sliding cover rod control lock, the rod control can be singly separated from lock body, left hand and right hand use can be realized by changing the cam position, single-point, two-point and three point cam are available;
- Remark: Applicable panel thickness: 1-8mm, the key K1010, K7010, K7030, K7040, K7050 are available(see page 83).



外形及安装孔尺寸 Dimensions of outline and cut out

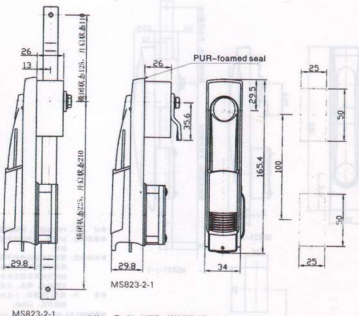

- 材 质: PA-66锁体, 镀锌钢板连杆;
- 表面处理: 沙面漆, 其它颜色可按要求定制;
- 结构功能: 带滑盖的右旋转锁半锁体, 带锁体与锁体可直接分离, 请按照锁体方向可实现左右开门通用, 可配单点、两点、三点锁匙;
- 备 注: 适用门板厚度: 1-8mm, 锁体开孔: □36h;
- Material: PA-66 body, rod m.s. zinc pl.
- Surface color: Black, other colors on request;
- Structure: Sliding cover rod control lock, the rod control can be singly separated from lock body, left hand and right hand use can be realized by changing the cam position, single-point, two-point and three point cam are available;
- Remark: Applicable panel thickness: 1-8mm.

Dimensions of outline and cut out 外形及安装孔尺寸

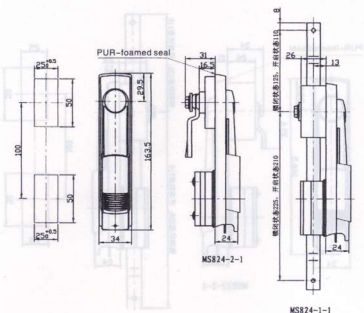

- 材 质: PA-66箱体, 镀锌钢板连杆
- 表面颜色: 沙面漆, 其它颜色可按客户要求
- 结构功能: 带薄盖的凸轮传动半圆锁, 传动体与箱体可直接分离, 调换锁转方向可实现左右开门通用, 可配单点、两点、三点锁。
- 备注: 适用门框厚度: 1-8mm, 锁体开孔: □26。
- Material: PA-66 body, rod m.s. zinc pl.
- Surface color: Black, other colors on request;
- Structure: Sliding cover rod control lock, the rod control can be singly separated from lock body, left hand and right hand use can be realized by changing the cam position, single-point, two-point and three-point cam are available.
- Remark: applicable panel thickness: 1-8mm.

Dimensions of outline and cut out 外形及安装孔尺寸

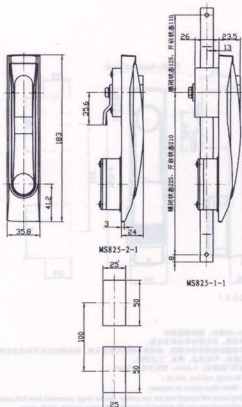

- 材 质: PA-66箱体, 镀锌钢板连杆;
- 表面颜色: 沙面漆, 其它颜色可按客户要求
- 结构功能: 带薄盖的凸轮传动半圆锁, 传动体与箱体可直接分离, 调换锁转方向可实现左右开门通用, 可配单点、两点、三点锁;
- 备注: 适用门框厚度: 1-2.5mm, 锁体开孔: □26。
- Material: PA-66 body, rod m.s. zinc pl.;
- Surface color: Black, other colors on request;
- Structure: Sliding cover rod control lock, the rod control can be singly separated from lock body, left hand and right hand use can be realized by changing the cam position, single-point, two-point and three-point cam are available;
- Remark: Applicable panel thickness: 1-2.5mm.

IP protection: IP55



MS824-2-1

MS825-1-1



MS825-2-1

IP protection:65



MS826-2-1

外形及安装孔尺寸 Dimensions of outline and cut out

- 材 质: 锌合金锁体, 镀锌钢板锁芯;
- 表面处理: 镀锌板、喷灰色、喷无光黑、喷沙处理;
- 结构功能: 外形可定制, 锁轴旋转方向可实现左右开门通用;
- 备 注: 适用门框厚度: 1-1.5mm, 锁体开孔: □8孔;
- Material: Zinc alloy body, cam m.s. zinc pl.;
- Finish: Gray chrome plating, bright chrome plating, black powder coated, matt black powder coated;
- Structure: Left hand and right hand use can be realized by changing the cam position;
- Remark: Applicable panel thickness: 1-1.5mm.

型号	尺寸	L1	L2
MS826-1-1	180	148.5	
MS826-2-1	120	109.8	

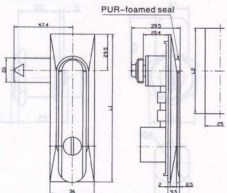

外形及安装孔尺寸 Dimensions of outline and cut out

- 材 质: 塑料锁体, 锌合金锁芯, 锁芯, 镀锌钢板锁芯;
- 表面处理: 镀锌板、喷灰色、喷无光黑;
- 结构功能: 圆形锁体平置锁, 锁轴旋转方向可实现左右开门通用;
- 备 注: 适用门框厚度: 1-1.5mm, 锁体开孔: □8孔;
- Material: Plastic lock base, zinc alloy knob and insert, cam m.s. zinc pl.;
- Finish: Gray chrome plating, bright chrome plating, black powder coated;
- Structure: Round lock, left hand and right hand use can be realized by changing the cam position;
- Remark: Applicable panel thickness: 1-1.5mm.

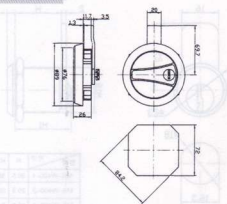

专利号(Patent No): 99333590.X



MS-W400-2A 双面弹子锁 Double face cylinder lock

外形及安装孔尺寸 Dimensions of outline and cut out

- 材 质: 锌合金锁体, 螺母, 镀锌钢板锁芯;
- 表面处理: 镀锌板、喷灰色、喷无光黑;
- 结构功能: 双面板子平置锁, 锁轴旋转方向可实现左右开门通用;
- 备 注: 适用门框厚度: 1-10mm, 专用锁2000把;
- Material: Zinc alloy body and nut, cam m.s. zinc pl.;
- Finish: Gray chrome plating, bright chrome plating, black powder coated;
- Structure: Left hand and right hand use can be realized by changing the cam position;
- Remark: Applicable panel thickness: 1-10mm, 2000 key combinations available.

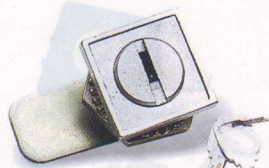
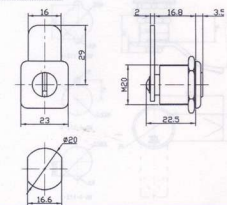

MS-W400-2B 双面弹子锁 Double face cylinder lock

外形及安装孔尺寸 Dimensions of outline and cut out

- 材 质: 锌合金锁体, 螺母, 镀锌钢板锁芯;
- 表面处理: 镀锌板、喷灰色、喷无光黑;
- 结构功能: 圆形平置锁, 锁轴旋转方向可实现左右开门通用;
- 备 注: 适用门框厚度: 1-10mm, 专用锁2000把;
- Material: Zinc alloy body and nut, cam m.s. zinc pl.;
- Finish: Gray chrome plating, bright chrome plating, black powder coated;
- Structure: Left hand and right hand use can be realized by changing the cam position;
- Remark: Applicable panel thickness: 1-10mm, 2000 key combinations available.

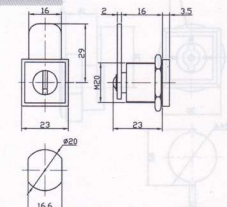

Dimensions of outline and cut out 外形及安装孔尺寸

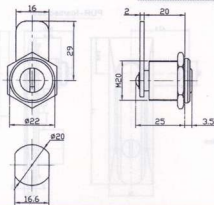

- 材料: 锌合金弹体、螺母、镀锌钢板弹体、钢板、钢板衬。
- 表面处理: 镀锌、镀铬、镀光亮铬、镀无光铬、黑粉涂层。
- 结构功能: 双弹子型防平面锁, 锁体朝左方向可实现左右开门通用。
- 备注: 适用门框厚度: 1-12mm, 专用康2000B。
- Material: Zinc alloy body and nut, cam m.s. zinc pl., brass key.
- Finish: Gray chrome plating, bright chrome plating, black powder coated.
- Structure: Left hand and right hand use can be realized by changing the cam position.
- Remarks: Applicable panel thickness: 1-12mm, 2000 key combinations available.



MS-W400-2D 双面弹子锁
Double face cylinder lock

Dimensions of outline and cut out 外形及安装孔尺寸

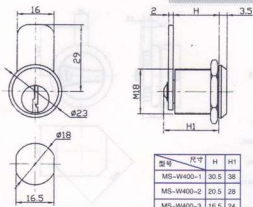

- 材料: 锌合金弹体、镀锌钢板弹体、螺母、钢板衬。
- 表面处理: 镀锌、镀铬、镀光亮铬、镀无光铬、黑粉涂层。
- 结构功能: 单弹子型防平面锁, 锁体朝左方向可实现左右开门通用。
- 备注: 适用门框厚度: 1-12mm, 专用康800B。
- Material: Zinc alloy body, cam and nut m.s. zinc pl., brass key.
- Finish: Gray chrome plating, bright chrome plating, black powder coated.
- Structure: Left hand and right hand use can be realized by changing the cam position.
- Remarks: Applicable panel thickness: 1-12mm, 80 key combinations available.



MS-W400-2 单向弹子锁

Dimensions of outline and cut out 外形及安装孔尺寸

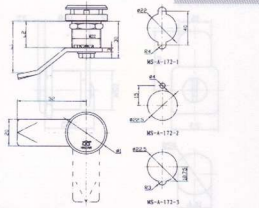

- 材料: 锌合金弹体、螺母、镀锌钢板弹体、螺母、钢板衬。
- 表面处理: 镀锌、镀铬、镀光亮铬、镀无光铬、黑粉涂层。
- 结构功能: 大面板型平面锁, 左右开门通用, 具有防水功能。
- 备注: 适用门框厚度: 1.5-8mm。
- Material: Zinc alloy body and nut, cam m.s. zinc pl.
- Finish: Gray chrome plating, bright chrome plating, black powder coated.
- Structure: Large size plane lock, both left hand and right hand use with waterproof function.
- Remarks: Applicable panel thickness: 1-12mm, 80 key combinations available.



MS-A-172-1

Dimensions of outline and cut out 外形及安装孔尺寸

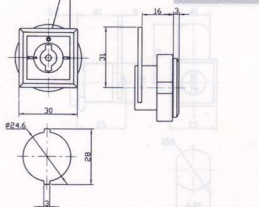

- 材料: ABS塑料、锌合金弹体和钢板、镀锌钢板弹体。
- 表面颜色: 黑色。
- 结构功能: 四方型平面锁, 左右开门通用。
- 备注: 适用门框厚度: 0.5-2.5mm。
- Material: ABS housing, zinc alloy insert and key, cam m.s. zinc pl.
- Surface color: Black.
- Structure: Square style lock, both left hand and right hand use.
- Remarks: Applicable panel thickness: 0.5-2.5mm.



MS200

Dimensions of outline and cut-out 外形及安装孔尺寸

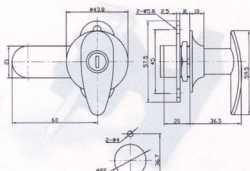

- 材 质: 锌合金壳体, 镀锌钢板锁芯;
- 表面处理: 镀锌铬、镀锌铬、抛光光面;
- 结构功能: L型把手, 锁芯旋转90°, 开孔方向决定左右开门/锁闭, 可配单点、两点、三点锁链;
- 备 注: 适用门板厚度: 1-1.5mm, 可配K200, k 1000, k8180钥匙(见第83页); 锁链开孔: □10x10.
- Material: Zinc alloy body, cam m.s. zinc pl.;
- Finish: Bright chrome plating, gray chrome plating, black powder coated;
- Structure: L handle lock, left hand and right hand use determined by the cut out, single-point, two-point and three-point cam are available.
- Remark: Applicable panel thickness: 1-1.5mm, the key K200, k 1000, k8180 are available(see page 83).



Dimensions of outline and cut-out 外形及安装孔尺寸

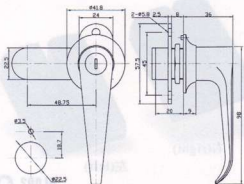

- 材 质: 锌合金壳体, 镀锌钢板锁芯;
- 表面处理: 镀锌铬、镀锌铬、抛光光面;
- 结构功能: L型把手, 锁芯旋转90°, 开孔方向决定左右开门/锁闭, 可配单点、两点、三点锁链;
- 备 注: 适用门板厚度: 1-1.5mm, 可配K200, k 1000, k8180钥匙(见第83页); 锁链开孔: □10x10.
- Material: Zinc alloy body, cam m.s. zinc pl.;
- Finish: Bright chrome plating, gray chrome plating, black powder coated;
- Structure: L handle lock, left hand and right hand use determined by the cut out, single-point, two-point and three-point cam are available.
- Remark: Applicable panel thickness: 1-1.5mm, the key K200, k 1000, k8180 are available(see page 83).

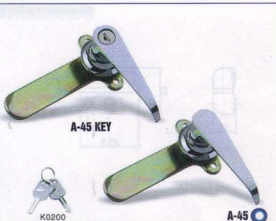

Dimensions of outline and cut-out 外形及安装孔尺寸

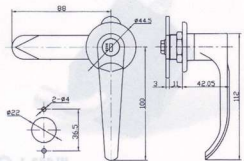

- 材 质: 锌合金壳体, 镀锌钢板锁芯;
- 表面处理: 镀锌铬、镀锌铬、抛光光面;
- 结构功能: L型把手, 锁芯旋转90°, 开孔方向决定左右开门/锁闭, 可配单点、两点、三点锁链;
- 备 注: 适用门板厚度: 1-1.5mm, 可配K200, k 1000, k8180钥匙(见第83页);
- Material: Zinc alloy body, cam m.s. zinc pl.;
- Finish: Bright chrome plating, gray chrome plating, black powder coated;
- Structure: L handle lock, left hand and right hand use determined by the cut out, single-point, two-point and three-point cam are available.
- Remark: Applicable panel thickness: 1-1.5mm, the key K200, k 1000, k8180 are available(see page 83).



Dimensions of outline and cut-out 外形及安装孔尺寸

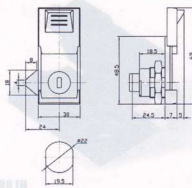

- 材 质: 锌合金壳体, 镀锌钢板锁芯;
- 表面处理: 镀锌铬、镀锌铬、抛光光面;
- 结构功能: 带防尘盖, 锁链锁闭方向可实现左右开门/锁闭;
- 备 注: 适用门板厚度: 1-5mm.
- Material: Zinc alloy body and nut, cam m.s. zinc pl.;
- Finish: Bright chrome plating, gray chrome plating, black powder coated;
- Structure: with dust cover, left hand and right hand use can be realized by changing the cam position;
- Remark: Applicable panel thickness: 1-5mm.



Dimensions of outline and cut out 外形及安装孔尺寸

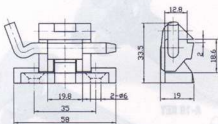

- 材 质: 锌合金壳, 静铰链, 分不锈钢和镀锌钢两种;
- 表面处理: 喷光亮黑, 喷沙灰黑, 喷沙铬, 喷亮铬;
- 结构功能: 静铰链, 左右开门通用, 门板转动角度约为180°;
- Material: Zinc alloy body, stainless steel and nickel plating steel pin are available;
- Finish: Black powder coated, matt black powder coated, gray chrome plating, bright chrome plating;
- Structure: 180° prominent hinge, both left and right use.

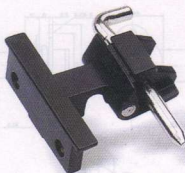

HL001

Dimensions of outline and cut out 外形及安装孔尺寸

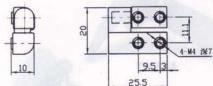

- 材 质: 锌合金铰链;
- 表面处理: 喷光亮黑, 喷沙灰黑, 喷沙铬, 喷亮铬;
- 结构功能: 静铰链, 有左右之分, 门板转动角度约为180°;
- Material: Zinc alloy body;
- Finish: Black powder coated, matt black powder coated, gray chrome plating, bright chrome plating;
- Structure: 180° prominent hinge, left or right use.



右(right)

左(left)

HL002

Dimensions of outline and cut out 外形及安装孔尺寸

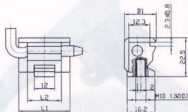

- 材 质: 锌合金壳, 静铰链, 分不锈钢和镀锌钢两种;
- 表面处理: 喷光亮黑, 喷沙灰黑, 喷沙铬, 喷亮铬;
- 结构功能: 静铰链, 左右开门通用, 门板转动角度约为180°;
- Material: Zinc alloy hinge, stainless steel and nickel plating steel pin are available;
- Finish: Black powder coated, matt black powder coated, gray chrome plating, bright chrome plating;
- Structure: 180° prominent hinge, both left and right use.



HL003-1

型号	尺寸	L1	L2	B1
HL003-1	40	26.5	20	25
HL003-2	30	20	16	

Dimensions of outline and cut out 外形及安装孔尺寸

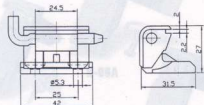

- 材 质: 锌合金壳, 静铰链, 分不锈钢和镀锌钢两种;
- 表面处理: 喷光亮黑, 喷沙灰黑, 喷沙铬, 喷亮铬;
- 结构功能: 静铰链, 左右开门通用, 门板转动角度约为180°;
- Material: Zinc alloy body, stainless steel and nickel plating steel pin are available;
- Finish: Black powder coated, matt black powder coated, gray chrome plating, bright chrome plating;
- Structure: 180° prominent hinge, both left and right use.



HL004



HL005

外形及安装孔尺寸 Dimensions of outline and cut out

- 材 质: 锌合金钢轴, 分不锈钢和镍铬钢轴两种;
- 表面处理: 抛光亮黑, 喷沙纹黑, 镀锌层, 镀镍层;
- 结构功能: 明铰链, 左右开门通用, 门板转动角度约为300°。
- Material: Zinc alloy body, stainless steel and nickel plating steel pin are available;
- Finish: black powder coated, matt black powder coated, gray chrome plating, bright chrome plating;
- Structure: 300° prominent hinge, both left and right use.

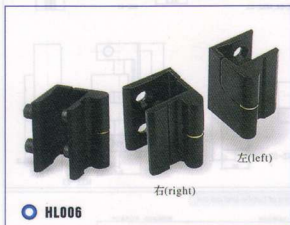
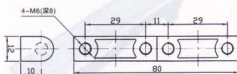

左(left)
右(right)

HL006

外形及安装孔尺寸 Dimensions of outline and cut out

- 材 质: 锌合金钢, 静铰链, 分不锈钢和镍铬钢轴两种, 嵌塞圈;
- 表面处理: 抛光亮黑, 喷沙纹黑, 镀锌层, 镀镍层;
- 结构功能: 明铰链, 有左右之分, 门板转动角度约为180°。
- Material: Zinc alloy body, stainless steel and nickel plating steel pin are available, brass washer;
- Finish: black powder coated, matt black powder coated, gray chrome plating, bright chrome plating;
- Structure: 180° prominent hinge, left or right use.

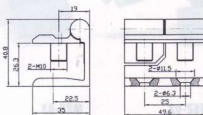

HL007

外形及安装孔尺寸 Dimensions of outline and cut out

- 材 质: 镀锌钢铰链;
- 表面处理: 镀锌层, 镀锌层;
- 结构功能: 明铰链, 左右开门通用, 门板转动角度约120°。
- Material: Zinc plating steel body;
- Finish: white zinc plating, color zinc plating;
- Structure: 120° prominent hinge, both left and right use.

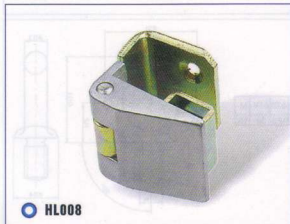
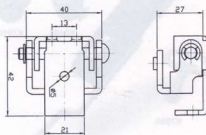

HL008

外形及安装孔尺寸 Dimensions of outline and cut out

- 材 质: 锌合金钢轴, 镀锌钢静铰链和活铰, 分不锈钢和镍铬钢轴两种;
- 表面处理: 抛光亮黑, 喷沙纹黑, 镀锌层, 镀镍层;
- 结构功能: 明铰链, 左右开门通用, 门板转动角度约180°。
- Material: Zinc alloy moving hinge, fixed hinge and living material (i.e. zinc, stainless steel and nickel plating steel pin are available);
- Finish: Black powder coated, matt black powder coated, gray chrome plating, bright chrome plating;
- Structure: 180° prominent hinge, both left and right use.

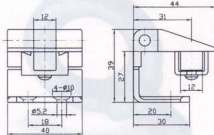



外形及安装孔尺寸 Dimensions of outline and cut out

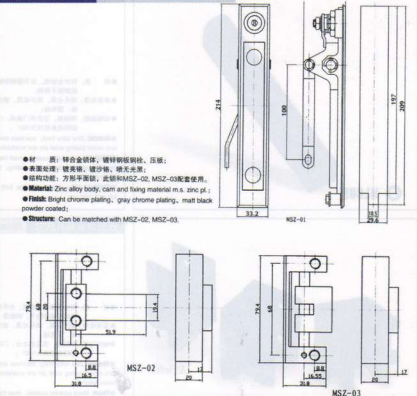

外形及安装孔尺寸 Dimensions of outline and cut out

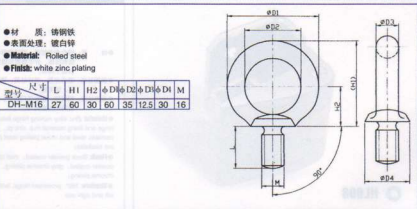
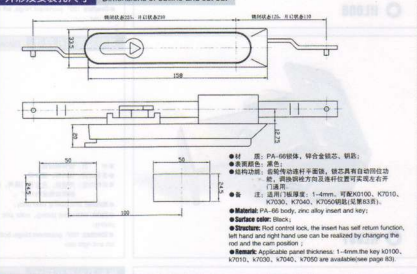

Dimensions of outline and cut out 外形及安装孔尺寸

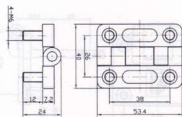

- 材 质: 锌合金壳, 静铰链, 分不锈钢和镀锌钢两种, 分不锈钢和镀锌钢两种。
- 表面处理: 喷光亮黑、喷沙纹黑、喷沙纹、喷铬亮。
- 结构功能: 静铰链, 左右开门通用, 门框转动角度约为180°。
- 注 意: 适用门板厚度: 1.2-6mm。
- Material: Zinc alloy hinge, stainless steel and nickel plating steel pin are available.
- Finish: Black powder coated, matt black powder coated, gray chrome plating, bright chrome plating.
- Structure: 180° prominent hinge, both left and right use.
- Remark: Applicable panel thickness: 1.2-6mm.



HL009

Dimensions of outline and cut out 外形及安装孔尺寸

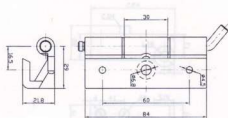

- 材 质: 锌合金壳, 静铰链, 分不锈钢和镀锌钢两种。
- 表面处理: 喷光亮黑、喷沙纹黑、喷沙纹、喷铬亮。
- 结构功能: 静铰链, 左右开门通用, 门框转动角度约为180°。
- Material: Zinc alloy hinge, stainless steel and nickel plating steel pin are available.
- Finish: Black powder coated, matt black powder coated, gray chrome plating, bright chrome plating.
- Structure: 180° concealed hinge both left and right use, no panel thickness limit.



HL010

Dimensions of outline and cut out 外形及安装孔尺寸

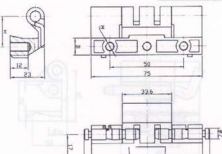

- 材 质: 锌合金静铰链, 镀锌钢动铰链, 镀锌钢销子。
- 表面处理: 喷光亮黑、喷沙纹黑、喷沙纹、喷铬亮。
- 结构功能: 静铰链, 静铰链铰链铰链, 左右开门通用, 门框转动角度约为180°。
- Material: Zinc alloy fixed hinge, zinc plating steel moving hinge, nickel plating steel pin.
- Finish: Black powder coated, matt black powder coated, gray chrome plating, bright chrome plating.
- Structure: 180° concealed hinge, both left and right use.



HL011-1

型号	尺寸	H	B	M
HL011-1	20.3	11.4	6	
HL011-2	19.8	7.8	4	

Dimensions of outline and cut out 外形及安装孔尺寸

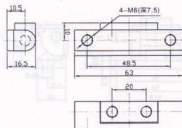

- 材 质: 锌合金壳, 静铰链, 分不锈钢和镀锌钢两种。
- 表面处理: 喷光亮黑、喷沙纹黑、喷沙纹、喷铬亮。
- 结构功能: 静铰链, 左右开门通用, 门框转动角度约为180°。
- Material: Zinc alloy body, stainless steel and nickel plating steel pin are available.
- Finish: Black powder coated, matt black powder coated, gray chrome plating, bright chrome plating.
- Structure: 180° prominent hinge, both left and right use.



HL012



HL013

外形及安装孔尺寸 Dimensions of outline and cut out

- 材 质: 锌合金, 静铰链, 分不锈钢和镍镀锌钢两种, 镀锌钢压板;
- 表面处理: 抛光亮黑, 喷沙纹黑, 喷沙纹, 喷亮铬;
- 结构功能: 静铰链, 左右开门通用, 门板转动角度约为180°;
- Material: Zinc alloy body, stainless steel and nickel plating steel pin are available; flang material m.s. zinc pl;
- Finish: black powder coated, matt black powder coated, gray chrome plating, bright chrome plating;
- Structure: 180° concealed hinge, both left and right use.

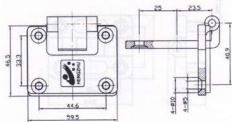

HL014

外形及安装孔尺寸 Dimensions of outline and cut out

- 材 质: 锌合金;
- 表面处理: 抛光亮黑, 喷沙纹黑, 喷沙纹, 喷亮铬;
- 结构功能: 静铰链, 左右开门通用, 门板转动角度约为180°;
- Material: Zinc alloy body;
- Finish: black powder coated, matt black powder coated, gray chrome plating, bright chrome plating;
- Structure: 180° prominent hinge, both left and right use.

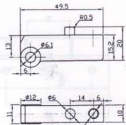

HL015

外形及安装孔尺寸 Dimensions of outline and cut out

- 材 质: 锌合金, 静铰链, 分不锈钢和镍镀锌钢两种;
- 表面处理: 抛光亮黑, 喷沙纹黑, 喷沙纹, 喷亮铬;
- 结构功能: 静铰链, 左右开门通用, 门板转动角度约为180°;
- 备注: 适用门板厚度: 1.2-2.0mm
- Material: Zinc alloy body, stainless steel and nickel plating steel pin are available;
- Finish: black powder coated, matt black powder coated, gray chrome plating, bright chrome plating;
- Structure: 180° prominent hinge, both left and right use;
- Remark: Applicable panel thickness: 1.2-2.0mm

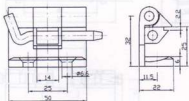

HL016

外形及安装孔尺寸 Dimensions of outline and cut out

- 材 质: 锌合金, 静铰链, 分不锈钢和镍镀锌钢两种;
- 表面处理: 抛光亮黑, 喷沙纹黑, 喷沙纹, 喷亮铬;
- 结构功能: 静铰链, 左右开门通用, 门板转动角度约为180°;
- 备注: 适用门板厚度: 1.2-2.0mm
- Material: Zinc alloy body stainless steel and nickel plating steel pin are available;
- Finish: black powder coated, matt black powder coated, gray chrome plating, bright chrome plating;
- Structure: 180° prominent hinge, both left and right use;
- Remark: Applicable panel thickness: 1.2-2.0mm

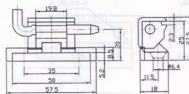

Dimensions of outline and cut out 外形及安装孔尺寸

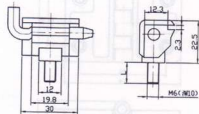

L=15为HL017-1, L=11为HL017-2

- 材 质: 锌合金、静纹铝, 分不锈钢和镍铬镀锌两种, 分不锈钢和镍铬镀锌两种。
- 表面处理: 喷光无漆、喷沙纹黑、喷沙纹、喷亮铬。
- 结构功能: 暗纹铝, 左右开门通用, 门板转动角度约为180°。
- 备 注: 适用门板厚度: 1.2-2.0mm。
- Material: Zinc alloy body, stainless steel and nickel plating steel pin are available; stainless steel and nickel plating stay screw are available.
- Finish: Black powder coated, matt black powder coated, gray chrome plating, bright chrome plating.
- Structure: 180° prominent hinge, both left and right use.
- Remark: Applicable panel thickness 1.2-2.0mm



HL017

Dimensions of outline and cut out 外形及安装孔尺寸

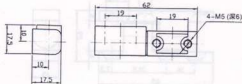

- 材 质: 锌合金;
- 表面处理: 喷光无漆、喷沙纹黑、喷沙纹、喷亮铬。
- 结构功能: 暗纹铝, 左右开门通用, 门板转动角度约为270°。
- Material: Zinc alloy body;
- Finish: Black powder coated, matt black powder coated, gray chrome plating, bright chrome plating.
- Structure: 270° prominent hinge, both left and right use.



HL018

Dimensions of outline and cut out 外形及安装孔尺寸

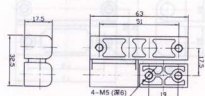

- 材 质: 锌合金;
- 表面处理: 喷光无漆、喷沙纹黑、喷沙纹、喷亮铬。
- 结构功能: 暗纹铝, 有左右开之分, 门板转动角度约为270°。
- Material: Zinc alloy body;
- Finish: Black powder coated, matt black powder coated, gray chrome plating, bright chrome plating.
- Structure: 270° prominent hinge left or right use.



HL019

Dimensions of outline and cut out 外形及安装孔尺寸

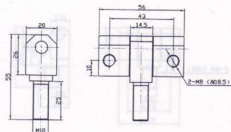

- 材 质: 锌合金、静纹铝, 分不锈钢和镍铬镀锌两种。
- 表面处理: 喷光无漆、喷沙纹黑、喷沙纹、喷亮铬。
- 结构功能: 暗纹铝, 左右开门通用, 门板转动角度约为270°。
- Material: Zinc alloy/stainless steel and nickel plating steel pin are available;
- Finish: Black powder coated, matt black powder coated, gray chrome plating, bright chrome plating.
- Structure: 270° prominent hinge, both left and right use.

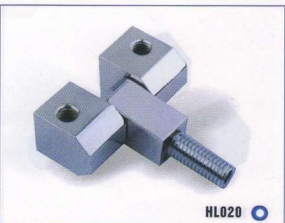

HL020

Dimensions of outline and cut out 外形及安装孔尺寸

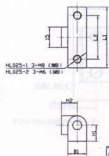

型号	尺寸	L1	L2	B1	H1	H2
HL025-1		63	43	16	13	13
HL025-2		45	32	14	11.8	11.8

- 材 质：锌合金、静镀锌，分不锈钢和镀锌钢两种，塑料垫圈。
- 表面处理：喷无光黑、喷沙纹黑、镀锌、镀镍。
- 结构功能：静镀锌，左右开门通用，门框转动角度的为180°。
- Material: Zinc alloy body, stainless steel and nickel plating steel pin are available, plastic washer.
- Finish: Black powder coated, matt black powder coated, gray chrome plating, bright chrome plating.
- Structure: 180° prominent hinge, both left and right use.



HL025-1

Dimensions of outline and cut out 外形及安装孔尺寸

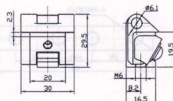

- 材 质：锌合金、静镀锌，分不锈钢和镀锌钢两种，镀锌垫圈。
- 表面处理：喷沙纹、喷无光黑、喷沙纹黑。
- 结构功能：静镀锌，左右开门通用，门框转动角度的为180°。
- 备 注：通用门框厚度：1.2-6.0mm。
- Material: Zinc alloy body, stainless steel and nickel plating steel pin are available, fixing material m.s. zinc pl.
- Finish: Black powder coated, matt black powder coated, gray chrome plating, bright chrome plating.
- Structure: 180° prominent hinge, both left and right use.
- Remark: Applicable panel thickness: 1.2-6.0mm.



HL026

Dimensions of outline and cut out 外形及安装孔尺寸

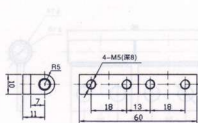

- 材 质：锌合金、静镀锌，分不锈钢和镀锌钢两种。
- 表面处理：喷无光黑、喷沙纹黑、镀锌、镀镍。
- 结构功能：静镀锌，左右开门通用，门框转动角度的为180°。
- Material: Zinc alloy body, stainless steel and nickel plating steel pin are available.
- Finish: Black powder coated, matt black powder coated, gray chrome plating, bright chrome plating.
- Structure: 180° prominent hinge, both left and right use.



HL027

Dimensions of outline and cut out 外形及安装孔尺寸

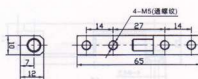

- 材 质：锌合金、静镀锌，分不锈钢和镀锌钢两种。
- 表面处理：喷无光黑、喷沙纹黑、镀锌、镀镍。
- 结构功能：静镀锌，左右开门通用，门框转动角度的为180°。
- Material: Zinc alloy body, stainless steel and nickel plating steel pin are available.
- Finish: Black powder coated, matt black powder coated, gray chrome plating, bright chrome plating.
- Structure: 180° prominent hinge, both left and right use.

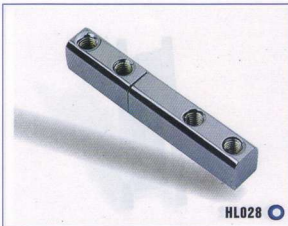

HL028

根据客户要求可配安装螺丝M5x12
M5x12 screw is available on request

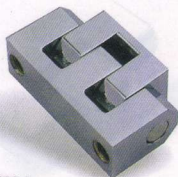

HL029-1

外形及安装孔尺寸 Dimensions of outline and cut out

- 材 质: 锌合金、锌铁合金、分不锈钢和镍镀锌钢两种;
- 表面处理: 喷光亮漆、喷沙纹漆、喷少锈、喷美锈;
- 结构功能: 铰链轴, 左右开门通用, 门板转动角度的为180°;
- Material: Zinc alloy body, stainless steel and nickel plating steel pin are available;
- Finish: Black powder coated, matt black powder coated, gray chrome plating, bright chrome plating;
- Structure: 180° prominent hinge, both left and right use.

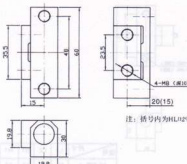

注: 括号内为HL029-2尺寸

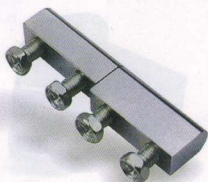

HL030

外形及安装孔尺寸 Dimensions of outline and cut out

- 材 质: 锌合金、锌铁合金、分不锈钢和镍镀锌钢两种;
- 表面处理: 喷光亮漆、喷沙纹漆、喷少锈、喷美锈;
- 结构功能: 铰链轴, 左右开门通用, 门板转动角度的为180°;
- Material: Zinc alloy body, stainless steel and nickel plating steel pin are available;
- Finish: Black powder coated, matt black powder coated, gray chrome plating, bright chrome plating;
- Structure: 180° prominent hinge, both left and right use.

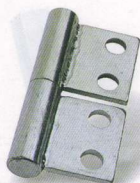
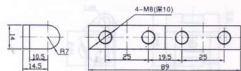

HL031

外形及安装孔尺寸 Dimensions of outline and cut out

- 材 质: 镀锌铁铰链;
- 表面处理: 喷白锌、喷美锈;
- 结构功能: 铰链轴, 左右开门通用, 门板转动角度的为270°;
- Material: M.s. hinge zinc pl.
- Finish: White zinc plating, color zinc plating;
- Structure: 270° prominent hinge, both left and right use.

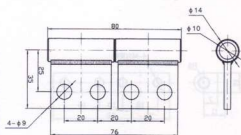

HL032

外形及安装孔尺寸 Dimensions of outline and cut out

- 材 质: 锌合金、锌铁合金、分不锈钢和镍镀锌钢两种;
- 表面处理: 喷美锈、喷少锈;
- 结构功能: 铰链轴, 左右开门通用, 门板转动角度的为180°;
- Material: Zinc alloy body, stainless steel and nickel plating steel pin are available;
- Finish: Bright chrome plating, gray chrome plating;
- Structure: 180° prominent hinge, both left and right use.

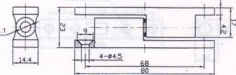

Dimensions of outline and cut out 外形及安装孔尺寸

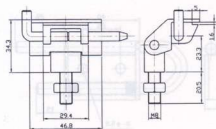

- 材 质: 锌合金壳、钢铰链, 分不锈钢和镀锌钢板子两种, 分不锈钢和镀锌钢铰链两种;
- 表面处理: 喷光无漆、喷沙效果、镀锌、镀黑铬;
- 结构功能: 明铰链, 左右开门通用, 门板铰链角度约为180°;
- 备 注: 铰链门板厚度: 1.0-1.5mm
- Material: Zinc alloy body, stainless steel and nickel plating steel pin are available, stainless steel and nickel plating alloy screw pin available.
- Finish: Black powder coated, matt black powder coated, gray chrome plating, bright chrome plating.
- Structure: 180° prominent hinge, both left and right use.
- Remark: Applicable panel thickness 1.0-1.5mm



HL033

Dimensions of outline and cut out 外形及安装孔尺寸

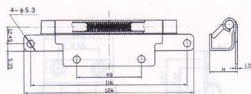

型号	尺寸	L1
HL034-1	23.4	
HL034-2	20	
HL034-3	17	

- 材 质: 镜面不锈钢;
- 结构功能: 暗铰链, 左右开门通用, 门板铰链角度约为120°;
- Material: Mirror surface stainless steel.
- Structure: 120° concealed hinge, both left and right use.



HL034-1

Dimensions of outline and cut out 外形及安装孔尺寸

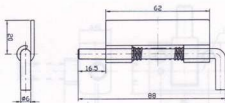

- 材 质: 镀锌钢铰链, 分不锈钢和镀锌钢板子两种;
- 表面处理: 镀锌、镀锌镍;
- 结构功能: 暗铰链, 左右开门通用, 门板铰链角度约为180°;
- Material: Zinc plating steel body, stainless steel and nickel plating steel pin are available;
- Finish: White zinc plating, color zinc plating.
- Structure: 180° concealed hinge, both left and right use.



HL035

Dimensions of outline and cut out 外形及安装孔尺寸

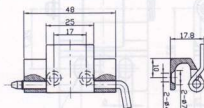

- 材 质: 锌合金钢铰链, 镀锌钢铰链, 分不锈钢和镀锌钢板子两种;
- 表面处理: 喷光无漆、喷沙效果、镀锌、镀黑铬;
- 结构功能: 暗铰链, 左右开门通用, 门板铰链角度约为120° (门板与固定铰链);
- Material: Zinc alloy fixed hinge, zinc plating steel moving hinge, stainless steel and nickel plating steel pin are available.
- Finish: Black powder coated, matt black powder coated, gray chrome plating, bright chrome plating.
- Structure: 120° prominent hinge, both left and right use. (fix the door and the moving hinge by welding).



HL036



HL045

外形及安装孔尺寸 Dimensions of outline and cut out

●材 质: 铸合金钢、静锻钢、塑料防腐用能防腐, 分不锈钢和镀锌钢两种, 分不锈钢和镀锌钢两种。

●表面处理: 喷丸处理、喷沙处理。

●结构功能: 明铰链, 左右开门通用, 门旋转角为180°。

●Material: Zinc alloy body, plastic weather cover, stainless steel and nickel plating steel pin are available, stainless steel and zinc plating entry screw are available.

●Finish: Black powder coated, matt black powder coated.

●Structure: 180° prominent hinge, both left and right use.

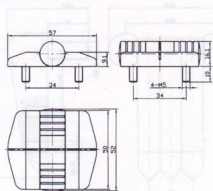

HL046

外形及安装孔尺寸 Dimensions of outline and cut out

●材 质: 铸合金钢、静锻钢, 分不锈钢和镀锌钢两种。

●表面处理: 喷沙处理、喷丸处理、喷沙处理。

●结构功能: 明铰链, 左右开门通用, 门旋转角为180°。

●Material: Zinc alloy body, stainless steel and nickel plating steel pin are available.

●Finish: Gray chrome plating, bright chrome plating, black powder coated, matt black powder coated.

●Structure: 180° prominent hinge, both left and right use.

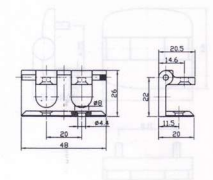

HL047

外形及安装孔尺寸 Dimensions of outline and cut out

●材 质: 铸合金钢、静锻钢, 分不锈钢和镀锌钢两种。

●表面处理: 喷沙处理、喷丸处理、喷沙处理。

●结构功能: 明铰链, 左右开门通用, 门旋转角为180°。

●Material: Zinc alloy body, stainless steel and nickel plating steel pin are available.

●Finish: Gray chrome plating, bright chrome plating, black powder coated, matt black p owder coated.

●Structure: 180° prominent hinge, both left and right use.

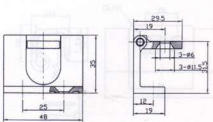

HL048

外形及安装孔尺寸 Dimensions of outline and cut out

●材 质: 镀锌钢板。

●表面处理: 喷沙处理、喷丸处理、喷沙处理。

●结构功能: 明铰链, 左右开门通用, 门旋转角为180°。

●Material: Zinc plating steel body.

●Finish: Color zinc plating, white zinc plating, nickel plating.

●Structure: 180° prominent hinge, both left and right use.

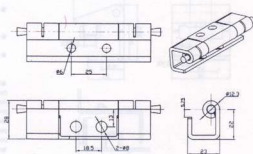

Dimensions of outline and cut out 外形及安装孔尺寸

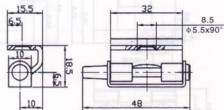

- 材 质: 镀锌钢板, 镀锌钢钉子;
- 表面处理: 镀锌; 镀锌; 镀锌;
- 结构功能: 明铰链, 左右开门通用, 门板转动角度为 180° ;
- Material: Zinc plating steel body, nickel plating steel pin;
- Finish: Color zinc plating, white zinc plating, nickel plating;
- Structure: 180° prominent hinge, both left and right use.

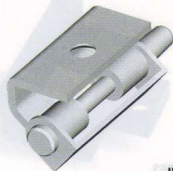

HL049

Dimensions of outline and cut out 外形及安装孔尺寸

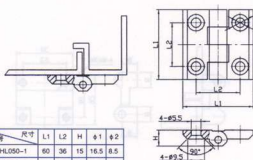

型号	尺寸	L1	L2	H	$\phi 1$	$\phi 2$
HL050-1		60	36	15	18.5	8.5
HL050-2		51	30	12	12.5	6
HL050-3		40	25	9	9.5	5.5

- 材 质: 锌合金, 静铰链, 分不锈钢和镀锌钢两种;
- 表面处理: 喷光无漆, 喷沙哑黑, 喷沙哑, 喷亮铬;
- 结构功能: 明铰链, 左右开门通用, 门板转动角度为 180° ;
- Material: Zinc alloy body, stainless steel and nickel plating steel pin are available;
- Finish: Black powder coated, matt black powder coated, gray chrome plating, bright chrome plating;
- Structure: 180° prominent hinge, both left and right use.

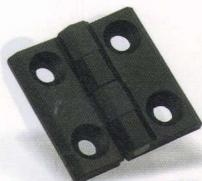

HL050-1

Dimensions of outline and cut out 外形及安装孔尺寸

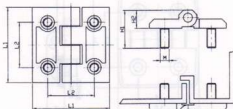

型号	尺寸	L1	L2	H1	H2	M
HL051-1		60	36	29	15	8
HL051-2		51	30	25	12	6
HL051-3		40	25	21	9	5

- 材 质: 锌合金, 静铰链, 分不锈钢和镀锌钢两种; 分不锈钢和镀锌钢螺钉;
- 表面处理: 喷光无漆, 喷沙哑黑, 喷沙哑, 喷亮铬;
- 结构功能: 明铰链, 左右开门通用, 门板转动角度为 180° ;
- Material: Zinc alloy body, stainless steel and nickel plating steel pin are available;
- Finish: Black powder coated, matt black powder coated, gray chrome plating, bright chrome plating;
- Structure: 180° prominent hinge, both left and right use.



HL051-1

Dimensions of outline and cut out 外形及安装孔尺寸

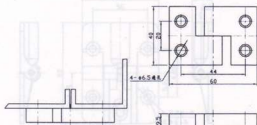

- 材 质: 锌合金, 静铰链, 分不锈钢和镀锌钢两种;
- 表面处理: 喷光无漆, 喷沙哑黑, 喷沙哑, 喷亮铬;
- 结构功能: 明铰链, 左右开门通用, 门板转动角度为 180° ;
- Material: Zinc alloy body, stainless steel and nickel plating steel pin are available;
- Finish: Bright chrome plating, gray chrome plating, black powder coated, matt black powder coated;
- Structure: 180° prominent hinge, both left and right use.



HL052

Dimensions of outline and cut out 外形及安装孔尺寸

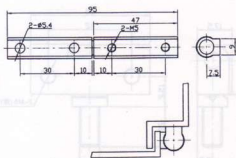

- 材 质: 镀锌钢或镍表面包不锈钢, 分不锈钢和镀锌钢两种;
- 表面处理: 镀锌, 镀白镍;
- 结构功能: 明铰链, 左右开门通用, 门旋转角度的为180°;
- Material: Zinc plating steel body with stainless steel cover, stainless steel and nickel plating steel pin are available;
- Finish: Color zinc plating, white zinc plating;
- Structure: 180° prominent hinge, both left and right use.



HL057

Dimensions of outline and cut out 外形及安装孔尺寸

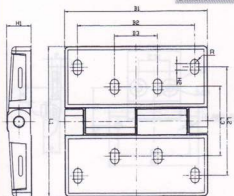

- 材 质: 锌合金, 镀锌钢, 分不锈钢和镀锌钢两种;
- 表面处理: 镀锌镍合金;
- 结构功能: 明铰链, 门旋转角度的为180°;
- Material: Zinc alloy body stainless steel and nickel plating steel pin are available; minor surface stainless steel cover, brass weather;
- Finish: Matt bright chrome plating;
- Structure: 180° prominent hinge, both left and right use.

型号	L1	L2	L3	B1	B2	B3	H1	H2	R
HL058-1	104	75	48	100	62	30	17	4.5	2.8
HL058-2	86	62	42	80	55	25	14.5	2.8	2.8
HL058-3	63	45.4	30.4	60	40	25	11.5	1.5	1.5

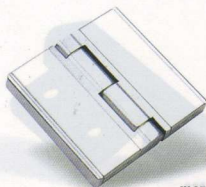

HL058-1

Dimensions of outline and cut out 外形及安装孔尺寸

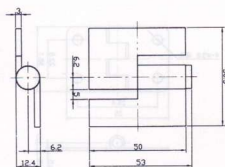

- 材 质: 镀锌钢铰链, 分不锈钢和镀锌钢两种;
- 表面处理: 镀锌镍, 镀白镍, 镀光亮黑;
- 结构功能: 暗铰链, 左右之分, 门旋转角度的为270°;
- Material: Zinc plating steel hinge, stainless steel and nickel plating steel pin are available;
- Finish: Color zinc plating, white zinc plating, black powder coated;
- Structure: 270° concealed hinge, left or right use.

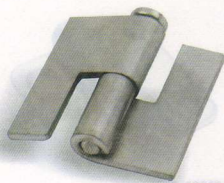

HL059

Dimensions of outline and cut out 外形及安装孔尺寸

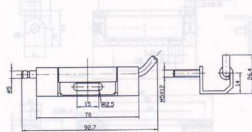

- 材 质: 镀锌钢铰链, 分不锈钢和镀锌钢两种;
- 表面处理: 镀锌镍, 镀白镍, 镀光亮黑;
- 结构功能: 暗铰链, 左右开门通用, 门旋转角度的为180°;
- Material: Zinc plating steel body stainless steel and nickel plating steel pin are available;
- Finish: Color zinc plating, white zinc plating, black powder coated;
- Structure: 180° concealed hinge, both left and right use.

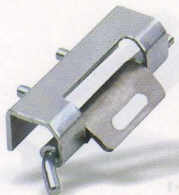

HL060

